

FOR DRAINS WITH TAPERED INSULATION AT DRAIN SUMP  
GREATER THAN 3" TO 1 HORIZONTAL FOOT (75 mm/300 mm)

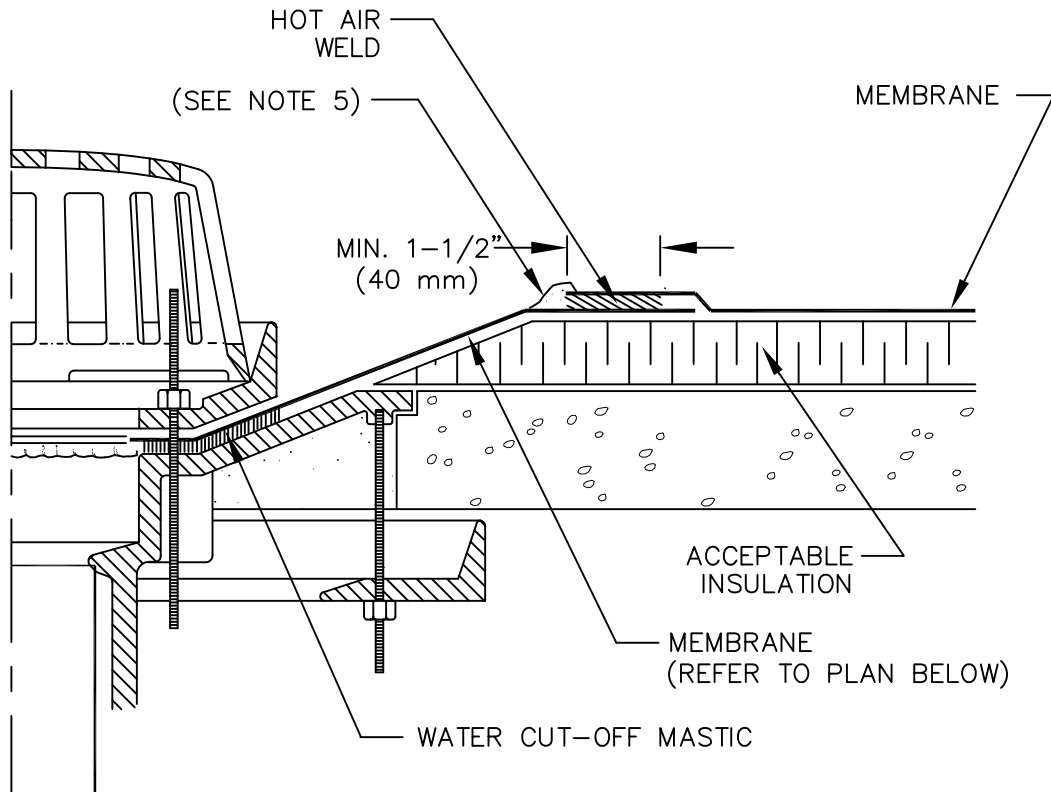

NOTES:

1. EXTEND THE REINFORCED MEMBRANE APPROXIMATELY 5-1/2" (140 mm) OUT OF THE SUMP AREA.
2. REMOVE ALL LEAD AND OTHER FLASHING.
3. ALL BOLTS OR CLAMPS MUST BE IN PLACE TO PROVIDE COMPRESSION ON WATER CUT-OFF MASTIC.
4. CUT THE MEMBRANE SO IT EXTENDS A MINIMUM OF 1/2" (13 mm) FROM THE ATTACHMENT POINTS OF THE DRAIN CLAMPING RING.
5. APPROXIMATELY 1/8" (3 mm) DIAMETER BEAD OF CUT-EDGE SEALANT IS REQUIRED ON CUT EDGE OF REINFORCED MEMBRANE.

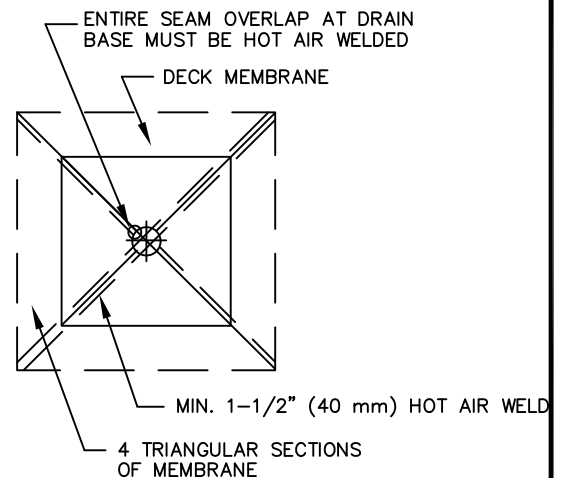

PLAN

VFC-6B

ROOF DRAIN-DRAIN SUMP GREATER THAN  
3 INCHES TO 1 HORIZONTAL FOOT

**VERSICO**  
ROOFING SYSTEMS

© 2008 VERSICO, LLC