

VERSIWELD ROOFING SYSTEM

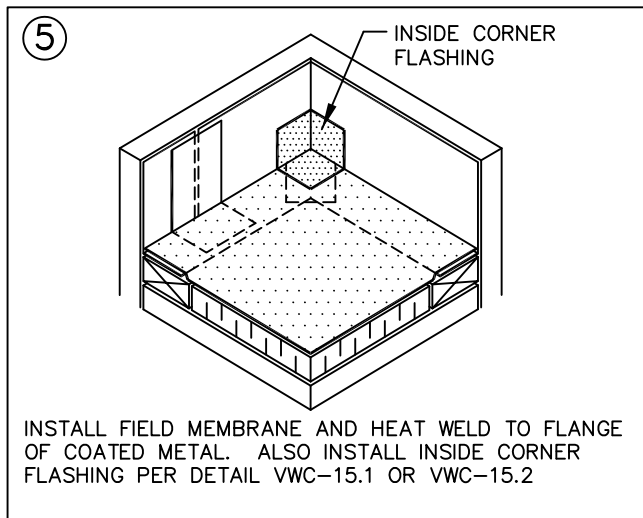
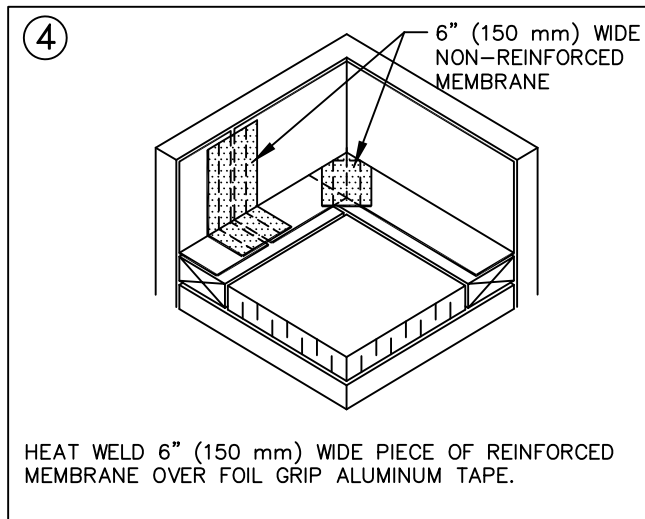
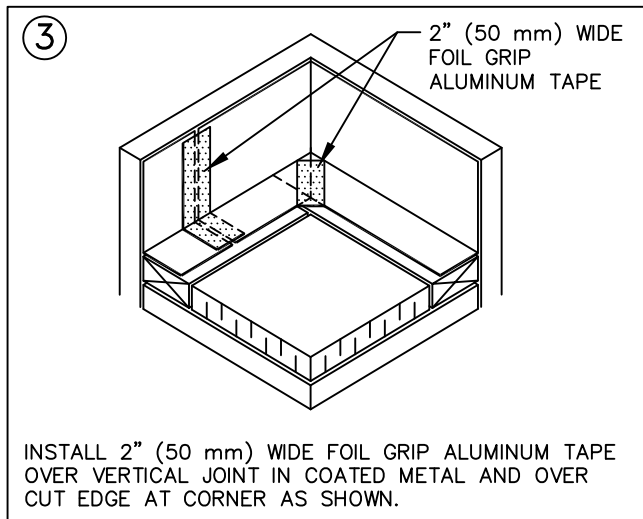
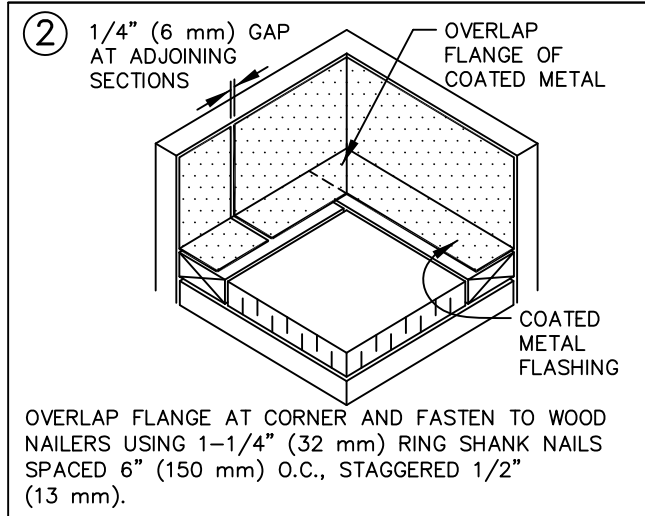
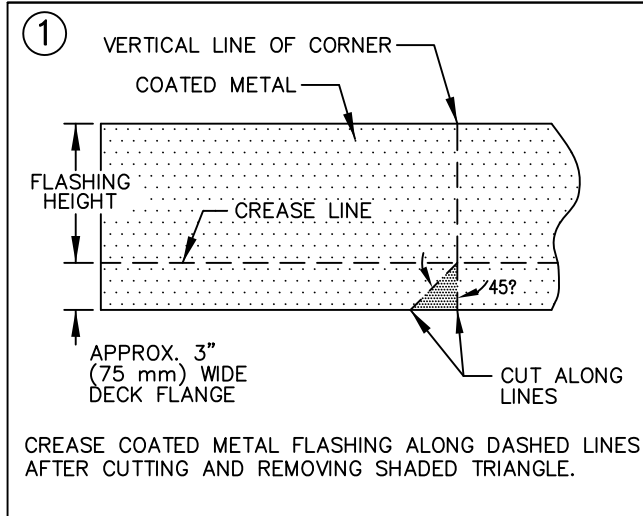

VWC-15.6
INSIDE CORNER WITH
COATED METAL WALL FLASHING