



# Mechanically Attached and Fully Adhered Roofing Systems

## Part I Design Criteria

### TABLE OF CONTENTS

April 2010

	Page
A. Description .....	2
B. General Design Considerations.....	2
C. Quality Assurance .....	4
D. Warranty.....	4
E. Code Approvals.....	5
F. Wood Nailers.....	5
G. Vapor Retarder.....	5
H. Roof Deck/Substrate Criteria .....	6
I. Insulation/Underlayment.....	7
J. Insulation Attachment.....	7
K. Membrane Securement Criteria .....	9
L. Membrane Splicing.....	9
M. Additional Membrane Securement .....	9
N. Flashing Considerations.....	10
O. Metal Work .....	10
P. Walkways .....	11

### ATTACHMENTS

Attachment I - Products/Coverage Rates.....	12
Attachment II - Withdrawal Resistance Criteria .....	16
Attachment III – Mechanically Attached Membrane Securement Criteria.....	18
Attachment IV – 10 or 15-Year Extended Warranty Wind Speed Coverage Design Criteria.....	25
Attachment V – 20-year Warranty – Design Enhancements .....	27
Attachment VI – Construction Generated Moisture .....	30
Attachment VII – Mechanically Attached 30-Year Warranty Design Enhancements.....	31
Attachment VIII – Fully Adhered 30-Year Warranty Design Enhancements.....	34

Revisions

April 2010      Revised Section B.



## Mechanically Attached and Fully Adhered Roofing Systems

### PART I Design Criteria August 2008

The information contained herein is to serve as criteria for specifiers regarding the design of this VersiWeld Mechanically Attached or Fully Adhered Roofing System. Specifiers are advised to fully familiarize themselves with this section and the applicable "Application" Section, Part II, prior to completing the project specifications.

Information pertaining to the products utilized with this roofing system can be found in "Attachment I", Products/Coverage Rates.

#### A. DESCRIPTION

1. The VersiWeld Mechanically Attached Roofing System incorporates 12', 10' or 8' wide, white, tan or gray 45, 60, 72 or 80-mil thick scrim-reinforced, VersiWeld Thermoplastic Polyolefin (TPO) membrane field sheets. Insulation is mechanically attached to an acceptable roof deck. VersiWeld perimeter sheets (5' or 6' used with 10' and 12' wide field sheets; 4' used with 8' wide field sheets) are installed along building edges and field membrane sheets are mechanically attached to the roof deck with the appropriate Versico Fasteners and Fastening Plates. Adjoining sheets of VersiWeld membrane are overlapped and joined together with a minimum 1-1/2" wide heat weld. Membrane fastening requirements are outlined in Attachment III at the end of this section.
2. The VersiWeld Fully-Adhered Roofing System incorporates maximum 12' wide white, gray or tan 45, 60, 72 or 80-mil thick scrim-reinforced VersiWeld Thermoplastic Polyolefin (TPO) membrane. Versico Insulation is mechanically attached to the roof deck or secured with FAST™ Adhesive, OlyBond 500 BA, OlyBond Spot Shot or Versigrip Insulation Adhesive and the membrane is fully adhered to the insulation with VersiWeld Bonding Adhesive. Adjoining sheets of membrane are overlapped approximately 2" and joined together with a minimum 1-1/2" wide heat weld.
3. These Roofing Systems can also be specified over an existing standing seam, flat seam or corrugated metal roof (Mechanically-Attached systems incorporate membrane securement into the structural purlins). Refer to the Metal Retrofit Roofing System Specification, published separately, for applicable requirements.

#### B. GENERAL DESIGN CONSIDERATIONS

1. The maximum roof slope for Mechanically Attached Roofing Systems is 18" in one horizontal foot. There are no maximum slope restrictions for the application of the Fully-Adhered Roofing System.
2. When roof slopes exceed 5" per horizontal foot, use of an Automatic Heat Welder may be more difficult. A Hand Held Hot Air Welder should be specified.
3. The mechanically attached roofing system is **not acceptable** for installations on steel decks lighter than 22 gauge unless the steel deck is used in conjunction with lightweight concrete and a minimum of 360 pounds pullout per fastener is achieved with HPVX Fasteners into the steel deck below. A Fully-Adhered Roofing System may be specified or refer to the Metal Retrofit Roofing System Specification, published separately for other roofing options.
4. Petroleum based products, certain chemicals and waste products may not be compatible with this roofing system. Versico must be contacted for verification of compatibility and recommendations concerning an acceptable roofing assembly.

5. The following projects should be sent to Versico for review prior to installation and preferably prior to bid to ensure that Versico's minimum warranty requirements are met:
  - a. Air pressurized buildings, canopies, and buildings with large openings where the total wall openings exceed 10% of the total wall area on which the openings are located (such as, airport hangars, warehouses and large maintenance facilities).
  - b. Cold storage buildings and freezer facilities.
6. It is the responsibility of the specifier to review local, state and regional codes to determine their impact on this VersiWeld Roofing System.
7. Coordination between various trades is essential to avoid unnecessary rooftop traffic over completed sections of the roof and to prevent subsequent damage to the VersiWeld membrane roofing system.
8. Concentrated loads from rooftop equipment may cause deformation of insulation/underlayment and possible damage to the membrane if proper protection is not provided. A protection course or sleepers must be specified.
9. The VersiWeld white (TPO) membrane meets the ENERGY STAR® Roofing Products program guidelines for energy efficiency. This product will help reduce energy costs. Energy savings is climate specific and may vary significantly from building to building and geographic location. The greatest savings will occur in buildings located in hot, sunny climates that have a large roof surface to building volume ratio, and lower levels of insulation with lesser thermal resistance.

For additional information on savings obtainable from installing the ENERGY STAR Roofing Product, contact Versico, one of Versico's Representatives/Distributors or call 1-888-STAR-YES (1-888-782-7937). For information regarding CRRC (Cool Roof Rating Council) and LEED™, refer to the applicable Technical Data Bulletins.

#### 10. Drainage

- a. Drainage must be evaluated by the specifier in accordance with all applicable codes. Slopes may be provided by tapering the structure or through the use of tapered insulation; a sufficient number of roof drains should also be specified and properly located to allow for positive drainage. Significant ponding that could remain after 48 hours should be eliminated with the addition of auxiliary drains in low areas where ponding is anticipated.

**Versico specifically disclaims responsibility for the design and selection of an adequate drainage system and drain accessories. Selection must be made by the building owner or the owner's design professional.**

- b. Small incidental areas of ponded water will not impact the performance of this roofing system; however, in accordance with industry standards, the roofing assembly **should be designed to prevent ponding** of water on the roof for prolonged periods (longer than 48 hours). Good roofing practice dictates proper drainage to prevent possible excessive live load and, in the event of a roof leak, to minimize potential interior damage to the roofing assembly and to the interior of the building.
  - c. **Tapered edge strips, crickets or saddles** are recommended where periodic ponding of water may occur. When the slope of the taper exceeds 2" to one horizontal foot, additional membrane securement at the base of the tapered edge strip will be required.
11. On new construction projects, especially in cold climate regions, moisture generated due to the construction process could adversely impact various components within the roofing assembly if not addressed. Refer to "Attachment VI," Construction Generated Moisture, for additional information.
  12. On structural concrete decks, when a vapor retarder is not used, gaps in the deck along the perimeter and around penetrations must be sealed along with vertical joints between tilt-up panels, if present, to prevent infiltration of hot humid air and possible moisture contamination resulting from condensation. This is specifically important when adhesive is used to attach the roof insulation.
  13. **Retrofit - Recover Projects** (when the existing roofing material is left in place)

- a. The removal of existing wet insulation and membrane must be specified. The specifier shall select an appropriate and compatible material as filler for voids created by removal of old insulation or membrane.
- b. Entrapment of water between old and new membrane can damage and deteriorate new insulation/underlayment between the two membranes. **If a vapor retarder or air barrier is not specified**, Versico recommends the existing membrane be perforated to avoid potential moisture accumulation to allow for detection of moisture to enable the building owner to take corrective action. This can be accomplished by drilling approximately 3/4" diameter holes every 100 square feet in the existing built-up roof or single-ply membrane (excluding PVC membrane).
- c. **Existing PVC** membrane may be totally removed or existing membrane must be cut into maximum 10' X 10' sections. All PVC flashings at the perimeter, roof drains and roof penetrations must be removed.

## C. QUALITY ASSURANCE

1. Versico recommends the use of Versico supplied products for use with VersiWeld Roofing Systems. The performance or integrity of products by others, **when selected by the specifier and accepted as compatible by Versico**, is not the responsibility of Versico and is **expressly disclaimed** by the Versico warranty.
2. This roofing system must be installed by a Versico Authorized Roofing Contractor in compliance with drawings and specifications as approved by Versico Incorporated.
3. There must be no deviations made from Versico's specifications or Versico's approved shop drawings without the **PRIOR WRITTEN APPROVAL** of Versico Incorporated.
4. After completion of the installation, upon request, an inspection shall be conducted by a Technical Representative of Versico to ascertain that the membrane roofing system has been installed according to Versico's published specifications and details applicable at the time of bid. This inspection is to determine whether a warranty shall be issued. It is not intended as a final inspection for the benefit of the owner.
5. The solar reflectance of this roofing product may decrease over time due to environmental defacement such as dirt, biological growth, ponded water, etc. The roof should be monitored at regular intervals and maintained or cleaned when necessary to assure the maximum solar reflectance. Refer to the appropriate "Application" Section, Part II, for cleaning procedures.

## D. WARRANTY

A Membrane System Warranty is available for roofing systems on commercial buildings within the United States and applies only to **products manufactured or marketed by Versico Incorporated**. The membrane system is defined as membrane, flashings, adhesives, sealants and other Versico brand products utilized in the installation. For a complete description of these products, refer to the "Attachment I" Products/Coverage Rates at the end of this section.

1. A **5-year Membrane System Warranty** is the minimum warranty required and will be issued for a charge.
2. A **10-year Membrane System Warranty** is also available for a charge
3. A **10 or 15-year Total Roofing System Warranty** is available for a charge at the time of purchase and requires that only materials from among those manufactured or marketed by Versico are to be specified and used to complete the roofing system. Some of the materials included are: insulation, membrane, flashing, adhesives, sealants, fasteners and plates and termination bars. Versico Edgings and Copings must also be specified when metal fascia systems are to be covered by the Versico Warranty.

Mechanically Attached Roofing Systems over cementitious wood fiber or gypsum decks, upon review, may receive a 15 year Total System Warranty when building height is not greater than 40' and a minimum of 3 perimeter sheets are utilized.

4. A **20-year Total System Warranty** is available for a charge for projects utilizing minimum 60-mil thick VersiWeld membrane and incorporating additional design enhancements as outlined in "Attachment V", 20-Year Warranty Design Enhancements, in this specification.

5. Standard peak gust wind speed coverage is 55 mph (measured 10 meters above ground). Greater wind speed coverage is available for projects incorporating additional design enhancements as outlined in "Attachment IV", Extended Warranty Wind Speed Coverage, in this specification

**CAUTION:** APPLICATIONS SUCH AS WALKING DECKS, TERRACES, PATIOS OR AREAS SUBJECTED TO CONDITIONS NOT TYPICALLY FOUND ON ROOFING SYSTEMS WILL NOT BE ELIGIBLE FOR A ROOFING SYSTEM WARRANTY.

#### 6. Access for warranty service

It shall be the owner's responsibility to expose the membrane in the event that warranty service is required when access is impaired. Such impairment includes, but is not necessarily limited to:

- a. Design features, such as window washer systems, which require the installation of traffic surface units in excess of 80 pounds per unit.
  - b. Any equipment, ornamentation, building service units and other top surfacing materials which are not defined as part of this specification.
  - c. Rooftop equipment that does not provide Versico with reasonable access to the membrane system for purposes of warranty investigation and related repairs.
  - d. Severely ponded conditions.
7. The formation or presence of mold or fungi in a building is dependent upon a broad range of factors including, but not limited to, the presence of spores and nutrient sources, moisture, temperatures, climatic conditions, relative humidity, and heating/ventilating systems and their maintenance and operating capabilities. These factors are beyond the control of Versico and Versico shall not be responsible for any claims, repairs, restoration or damages relating to the presence of any irritants, contaminants, vapors, fumes, molds, fungi, bacteria, spores, mycotoxins, or the like in any building or in the air, land, or water serving the building.

### E. CODE APPROVALS

1. Building codes are above and beyond the intended purpose of this specification. The respective **owner** or **specifier** should consult local codes for applicable requirements and limitations.
2. For **code approvals** with Versico's VersiWeld Roofing Systems, refer to the VersiWeld Code Approval Guide, published separately, Factory Mutual (FM) Approval Guide or Underwriters Laboratories (UL) Fire Resistance or Roofing Materials and Systems Directories.

### F. WOOD NAILERS

A **horizontal wood nailer** is used to provide an effective substrate for some installation details or other roof accessories. In addition, it is used to provide solid protection for edges of the membrane underlayment. Minimum thickness of the nailer must be such that the top of the nailer is flush with the top of the membrane underlayment.

1. Wood nailers are required for the securement of metal edgings, scuppers, and insulated pipes. **Parapet walls and most curbs do not require the utilization of wood nailers.**

**Note:** The width of the wood nailers must be specified to exceed the width of the metal flange of edgings and insulated metal collars.

2. When treated lumber is specified, it is recommended that only lumber, which has been pressure treated with salt preservatives be specified. Lumber treated with any of the wood preservatives such as, Creosote, Pentachlorophenol, Copper Naphthenate and Copper 8-quinolinolate will adversely affect the FleeceBACK membrane when in direct contact and are, therefore, unacceptable.

If non-treated lumber is to be specified, it must be stored to protect from moisture sources. A seal should be provided between the non-treated lumber and the concrete or gypsum substrate (similar to a sill sealer).

3. Methods used to fasten the nailer vary with building conditions; however, it is essential that secure attachment of durable stock be accomplished with non-corrosive fasteners. Factory Mutual Loss Prevention Data Sheet 1-49 (Perimeter Flashing, June 1985) contains options for the spacing and sizing of fasteners.

## G. VAPOR RETARDER

Versico does not require a vapor retarder for the protection of the membrane; however, the following criteria should be considered by the specifier.

1. The use of a vapor retarder to protect insulation and reduce moisture accumulation within an insulated roofing assembly should be investigated by the specifier, especially on projects with high interior humidity, such as, swimming pools, breweries, pulp mills, etc.
2. In the generally temperate climate of the United States, during the winter months, water vapor flows upward from a heated, more humid interior toward a colder, drier exterior. Vapor retarders are more commonly required in northern climates than in southern regions, where downward vapor pressure may be expected and the roofing membrane itself becomes the vapor retarder.
3. On cold storage/freezer facilities, the perimeter details must be selected to provide an air seal and prevent outside air from infiltrating and condensing within the roofing assembly.
4. Consult the latest publications by ASHRAE (American Society of Heating, Refrigerating and Air-Conditioning Engineers, Inc.) and NRCA (National Roofing Contractors Association) for specific information.

## H. ROOF DECK/SUBSTRATE CRITERIA

1. Proper decking shall be provided by the building owner. The building owner or its designated representative must ensure that the building structure is investigated by a registered engineer to assure its ability to withstand the total weight of the specified roofing system, as well as construction loads and live loads, in accordance with all applicable codes. The specifier must also designate the maximum allowable weight and location for material loading and storage on the roof.
2. The following chart identifies the acceptable roof decks/substrates and the minimum underlayment requirements.

Construction Type	Acceptable Roof Deck/Substrate	Mechanically Attached	Fully Adhered
New Construction	Steel (min. 22 gauge) (1) (2), Wood Plank (3/4" min.) and Fibrous Cement	Insulation	Insulation
	Structural Concrete (min. 3000 psi) or Gypsum	Insulation	Direct Application
	Plywood (min. 15/32" thick) or Oriented Strand Board (min. 7/16" thick)	Direct Application	Direct Application
	Lightweight Insulating Concrete	Direct Application	Direct Application (10)
Retrofit/No Tearoff	Existing Smooth Surface BUR (3) or Mineral Surface Cap Sheet	Direct Application (6)	Direct Application (6)
	Gravel Surfaced BUR (4) or Coal Tar Pitch (4) (5)	Insulation	Insulation
	Existing Single-Ply	Direct Application (8)	Insulation
	Modified Bitumen	Direct Application(6) (9)	Direct Application(6) (9)
	Sprayed-in-Place Urethane	Complete Tearoff Required	Complete Tearoff Required
Retrofit/Tearoff	Existing roof material removed (regardless of deck type)	Insulation	Insulation

**Notes:**

Refer to Paragraph I, Insulation/Underlayment, for various Versico insulations approved with this roofing system.

- (1) Local codes must be consulted regarding thermal barrier requirements.
- (2) Mechanically Attached Systems cannot be specified on steel decks less than 22 gauge or for corrugated steel decks, regardless of gauge. Refer to the Metal Retrofit Roofing System Specification, published separately, for installation options.
- (3) Existing Type III or IV smooth asphalt BUR only.
- (4) Loose gravel must be removed to avoid entrapment of moisture.
- (5) Existing coal tar could drip into the building, especially when new insulation does not provide sufficient thermal value to prevent the surface of the coal tar from softening.
- (6) Possible staining/discoloration of the membrane may result when installing this system directly over existing smooth surfaced BUR or modified bitumen. If aesthetics are critical, an approved insulation should be specified beneath the membrane.
- (7)
- (8) An approved underlayment is **required** over existing ballasted single-ply systems and PVC roofing systems of any type.
- (9) Direct application permitted over smooth surfaced modified bitumen. Membrane shall be positioned with length of sheets parallel to modified bitumen field seams. At end laps or other locations where Seams intersect modified bitumen field seams. 6" wide VersiWeld Flashing must be heat welded over intersections.
- (10) New approved cellular or perlite lightweight insulating concrete must have a minimum compressive strength of 225 psi. Except when the lightweight concrete is poured over slotted steel decks, pressure relief vents must be installed every 2,000 square feet in accordance with Versico Detail VWA-8. Direct application is not permitted where lightweight concrete is poured over an existing roofing material. Equilibrium moisture content after hydration/curing shall not exceed 12%. Refer to Part II "Application", Attachment III for additional requirements.

- 3. Withdrawal resistance tests are required for Versico's approval on certain types of roof decks. Refer to "Attachment II" at the end of this section for identification of approved decks and proper procedures for conducting pullout tests.
- 4. For direct application over an acceptable roof deck/substrate as outlined on the chart above, the substrate must be smooth, steel trowel finished (structural concrete), free of debris, protrusions, sharp edges and loose and foreign material. Cracks or voids in the substrate, greater than 1/4", must be filled with an appropriate material.
- 5. On retrofit projects, all existing phenolic insulation must be removed.

**I. INSULATION/UNDERLAYMENT**

**1. General**

- a. Roof insulation thickness must be determined by the thermal value required for each project and may be subject to code approval limitations. On projects where a vapor retarder is used, the specifier must calculate insulation thickness to ensure the temperature at the vapor retarder will not fall below the calculated dew point.
- b. Multiple layers of insulation are recommended with all joints staggered between layers.

2. **Versico Insulation/underlayment must be specified for all Total System Warranty projects or when the insulation is to be covered by the Versico Warranty.** Any of the Versico underlayments listed may be specified:

Versico Insulation	Minimum Thickness	Mechanically Attached	Fully Adhered
HP Recovery Board	1/2"	Acceptable (1)	Acceptable (1)
Dens-Deck/Dens-Deck Prime	1/4"	Acceptable (6)	Acceptable (Dens-Deck Prime only) (6)
EPS Composite Board	1-1/4"	Acceptable (2,3)	Acceptable (2,3)
EPS overlaid with HP Recovery Board or Dens-Deck/Dens Deck Prime	1-1/4"	Acceptable (2,3)	Acceptable (2,3)
Dow Styrofoam or Recovermate Extruded Polystyrene	1/2"	Acceptable (2,3,4,5)	Not Acceptable (must be overlaid with approved insulation)
Polyisocyanurate HP-H	1"	Acceptable	Acceptable

**Notes:**

- (1) 1/2" thick HP Recovery Board cannot be specified as the sole membrane underlayment over wide rib (Type B) or intermediate rib (Type F) steel decks. HP Recovery Board must be at least specified with 1/2" thick gypsum board or 3/4" thick perlite.
- (2) Local codes must be consulted regarding the acceptance of expanded or extruded polystyrene insulation directly over steel decks.
- (3) EPS, the EPS surface of EPS Composite Board, or Dow roof insulation cannot be installed directly over coal-tar pitch roof surfaces.
- (4) Dow insulation cannot be installed directly over existing PVC membranes. A layer of protective mat must be specified as a separator.

(5) Dow insulation cannot be installed directly under gray or tan VersiWeld membrane.  
(6) Dens-Deck/Dens-Deck Prime is recommended for use on top of an approved insulation. Their direct use over an existing roofing membrane or monolithic roof deck is not permitted for projects with a 20-year warranty.  
**Tapered EPS, Dow Deckmate or Deckmate Plus and Polyisocyanurate Insulations are also available.**

- 3. For 5 or 10-year non-Total System Warranty projects, Hunter Panels Polyisocyanurate Insulation may be specified. Insulation by others is not included in the coverage provided by the Versico Warranty.

**Restrictions:**

- a. Versico Roofing Systems cannot be specified in conjunction with Phenolic Insulation.
- b. Fiberglass insulation cannot be specified, even if overlaid with additional insulation.
- c. Do not specify perlite boards directly under the membrane.

## J. INSULATION ATTACHMENT

For all Total System Warranty projects and those projects where the insulation attachment method is to be covered by the Versico System Warranty, the use of Versico Fasteners and Plates or FAST™ Adhesive is required. Fasteners and plates (minimum 3" diameter), supplied by others may be used to **attach insulation** on Mechanically Attached and Fully Adhered Roofing Systems when the fastening assembly is Factory Mutual approved, recommended by the respective manufacturer and accepted by Versico prior to installation.

### 1. Mechanically Attached Roofing Systems

- a. **Versico Insulation** must be mechanically attached to the roof deck with Versico Fasteners and Seam Fastening Plates or Insulation Plates as follows.
  - 1) For minimum 1/2" thick Versico HP Recovery Board, minimum 1/4" thick Dens-Deck® or minimum 1-1/2" thick Polyisocyanurate insulation, a minimum of 5 fasteners and plates per 4' X 8' board (1 per 6.4 square feet) is required. For 4' X 4' boards, a minimum of 4 fasteners and plates (1 per 4 square feet) shall be used. Refer to Detail VWMA-27A for fastening requirements.
  - 2) For Versico Polyisocyanurate insulation less than 1-1/2" in thickness or Dow Extruded Polystyrene insulation, any thickness (for use with white VersiWeld membrane only), a minimum of 6 fasteners and plates per 4' X 8' board (1 per 5.3 square feet) and 4 fasteners and plates per 4' X 4' board (1 per 4 square feet) must be utilized. Refer to Detail VWMA-27.1 (Polyisocyanurate insulation) or VWMA-27.2B (DOW insulation) for fastening requirements.
- b. Gypsum board may be specified as a membrane underlayment to meet certain fire ratings. Refer to Versico's VersiWeld Code Approval Guide for specific information. Gypsum board must be fastened at the same rate as Versico HP Recovery Board as noted above.
- c. Hunter Panels Polyisocyanurate Insulation, when specified on non-Total System Warranty project, must be mechanically attached to the roof deck in accordance with the insulation manufacturer's recommendations.

### 2. Fully Adhered Roofing Systems

- a. Versico **Insulation** must be mechanically secured to the roof deck with **one 3" diameter plate and fastener every 2 square feet except as follows:**

For structural concrete, minimum 22 gauge steel, 1" wood planks or 15/32" thick plywood decks:

- 1) When a single or top layer of **minimum 1-1/2" thick Versico Polyisocyanurate** is specified, the Versico Insulation may be secured at the minimum rate of 1 per 3.2 square feet (**10 Versico Fasteners and Plates per 4' x 8' board; 5 fasteners per 4' x 4' board**).

- 2) When a single or top layer of **minimum 2" thick Versico Polyisocyanurate** Insulation is specified, the Versico insulation may be mechanically secured with **one Versico Fastener and Plate every 4 square feet**.
- 3) Dens-Deck Prime (1/4" or 1/2" thick) may be fastened at the rate of 12 fasteners/plates per 4' x 8' board (1 per 2.67 square feet). Dens-Deck Prime (5/8" thick) may be fastened at the rate of 8 fasteners/plates per 4' x 8' board (1 per 4 square feet).

**Note:** If a wind speed warranty greater than 55 mph is desired or a 20-year warranty is specified, additional insulation fastening may be required. Refer to Attachment IV and/or Attachment V at the end of this section for criteria.

- 4) **On reroof/no tearoff projects** with a maximum roof height of 40' **any Versico insulation** (i.e., HP Recovery Board, Polyisocyanurate Insulation less than 1-1/2" thick) may be secured at the minimum rate of **11 fasteners per 4' x 8' board (5 fasteners per 4' x 4' board)**. This option is **not applicable for 15 or 20-year Golden Seal Warranty projects** or projects where extended wind speed coverage (greater than 55 mph) is desired.
- b. Hunter Panels Polyisocyanurate Insulation, when specified on non-Total System Warranty project, must be mechanically attached to the roof deck in accordance with the insulation manufacturer's recommendations.
  - c. When an approved oriented strand board (OSB) is specified as the membrane underlayment, it must be mechanically attached to the roof deck in accordance with Versico Detail VWA-27.4. If OSB is to be specified in conjunction with FAST Adhesive (for insulation attachment), an OSB/Polyiso composite board is recommended. Refer to Attachment IV in Part II Application.
  - d. For projects specified to achieve a Factory Mutual (FM) rating, additional insulation fasteners will be required at roof perimeter and corners. Refer to Versico's VersiWeld Code Approval Guide or Factory Mutual Loss Prevention Data Sheets 1-28 and 1-29 or for specific requirements.

**e. Alternate Insulation Attachment Methods**

- 1) **Versico FAST Adhesive**, a 100% spray-applied or bead-applied, two-component, low-rise urethane adhesive may be specified for insulation attachment in lieu of mechanical securement. **Refer to Attachment IV** in Part II, Application in the VersiWeld Fully-Adhered Roofing System Specification.
- 2) Versico OlyBond 500 BA or Spot Shot , a two-component polyurethane adhesive applied in approximately 1/2" - 3/4" beads spaced a maximum of 12" on center in the field of the roof and 6" on center at the perimeter (based on building height) may be utilized. Refer to the applicable Versico Technical Data Bulletin for specific installation instructions.
- 3) Versico Versigrip Insulation Adhesive, a one-component, moisture-curing, polyurethane adhesive applied in approximately 1/2"- 3/4" beads spaced a maximum of 12" on center in the field of the roof and 6" on center at the perimeter (based on building height) may be utilized. Refer to the applicable Versico Technical Data Bulletin for specific installation instructions.
- 4) The building owner or specifier may select an alternate insulation attachment method, which incorporates a **solid mopping** of insulation **with hot asphalt**. **Refer to "Attachment V"** in Part II, Application, in the VersiWeld Fully-Adhered Roofing System for applicable requirements when this alternate insulation attachment method is specified.
- 5) When adhesive marketed by others is specified, contact the respective manufacturer regarding specific installation requirements and available warranty coverage. Versico warranties exclude products not supplied or marketed through Versico.

## **K. MEMBRANE SECUREMENT CRITERIA**

### **1. Mechanically Attached Roofing Systems (membrane fastening)**

- a. Versico Fasteners and Fastening Plates must be used for membrane securement and are dependent on the roof deck type. Refer to "Attachment II", Withdrawal Resistance Criteria, at the end of this section, for specific fastener and plate requirements.
- b. The **field and perimeter membrane width and fastening** requirements are **dependent** upon the project **wind zone, building height and deck type** and are outlined in "Attachment III" at the end of this section.

## 2. Fully-Adhered Roofing System (membrane bonding)

Maximum 12' wide VersiWeld Membrane is fully adhered to an approved insulation or substrate with VersiWeld Bonding Adhesive or VersiWeld Low VOC Bonding Adhesive. The Bonding Adhesive shall be applied to both the membrane and the surface to which it is being bonded at a coverage rate of approximately 60 square feet per gallon per finished surface (includes coverage on both membrane and the substrate).

As an option, AquaBase™ 120 Bonding Adhesive (water-based) may be used when applied to both the membrane and the surface to which it is being bonded at a coverage rate of approximately 120 square feet per gallon per finished surface (includes coverage on both membrane and the substrate).

## L. MEMBRANE SPLICING

Adjoining sheets of VersiWeld Membrane are heat welded using an Automatic Heat Welder or Hot Air Hand Welder and silicone roller. For specific installation requirements, refer to the applicable Part II, Application Section in the VersiWeld Specifications.

## M. ADDITIONAL MEMBRANE SECUREMENT

Additional membrane securement is required at the perimeter of each roof level, roof section, curb, skylight, interior wall, penthouse, etc., at any inside angle change where slope or combined slopes exceed 2" in one horizontal foot, and at other penetrations in accordance with the applicable Versico details.

Securement may be achieved as follows:

1. On **Mechanically Attached Roofing Systems**, Versico's HPVX or HPV-XL Fastening Plates are used to secure membrane at the base of walls and penetrations and flashed as shown on the applicable Versico detail (excluding OSB, cementitious wood fiber and gypsum decks where required Versico Fastener is installed with associated 2" diameter plate). On **Fully-Adhered Roofing Systems**, Versico standard 2" diameter Seam Fastening Plates may be used in lieu of HPVX Plates.
2. As an option, **TPO PS RUSS** 6" wide strip of reinforced VersiWeld membrane, may be installed in conjunction with Versico Fasteners and 2" diameter Seam Fastening Plates spaced a maximum of 12" on center below the membrane (HPVX or HPV-XL Fasteners and HPVX or HPV-XL Plates are required for Mechanically Attached Roofing Systems over steel and wood decks). The securement strip shall be installed horizontally at the base of walls or penetrations.

The underside of deck membrane is primed with TPO Primer, spliced to the RUSS and continued as wall flashing resulting in continuous membrane flashing without penetration of the deck membrane.

3. On **Mechanically Attached Roofing Systems**, when mechanical securement is not provided in some of the VersiWeld Details (i.e., pipes and sealant pockets), additional Fastening Plates must be used for membrane securement. The plates must be positioned a maximum of 12" away from the penetration, spaced a maximum of 12" on center and flashed in accordance with the applicable Versico Detail.

## N. FLASHING CONSIDERATIONS

1. The height of new wall flashing must extend above the anticipated water level or slush line.
2. Bonding Adhesive is not required on vertical surfaces (walls, curbs, pipes, etc.) when flashing height is 12" or less and the membrane is terminated under metal counterflashing. When a coping or termination bar is used for the vertical termination, Bonding Adhesive may be eliminated when flashing height is 18" or less.
3. On Total System Warranty projects, Versico's Termination Bar, in conjunction with Water Cut-Off Mastic, must be specified under all metal counterflashings and surface mounted reglets.
4. **On retrofit projects**
  - a. The removal of existing loose flashing should be specified. New flashing must not extend above through-wall counterflashing and must not conceal any weep holes.

- b. The specifier must examine structural supports for rooftop equipment to determine if reasonable access to the membrane beneath the equipment is provided. Versico should be consulted for clarification when access to the membrane system will be restricted.
5. Bitumen based roof cement must be removed or concealed with an acceptable membrane underlayment.
6. When hot pipes or other similar penetrations exceed 120° F, they must be designed to incorporate an insulated metal collar and rain hood designed to maintain a surface temperature less than 120° F.

#### 7. Roof Drains

It is recommended that roof drain sumps be designed with slopes less than 3" to one horizontal foot to avoid additional membrane securement. When a greater slope is necessary in the roof drain sump area, additional membrane securement will be required. Refer to Detail VWC-6.2.

### O. METAL WORK

1. When a compression bar termination is to be specified, the use of Versico's Termination Bar is recommended.
2. Termination bars and surface mounted reglets must be installed directly to the wall surface.
3. Versico recommends VersiWeld Coated Metal, Versico VersiTrim™ Metal Edging/Coping, VersiTrim Metal Edging or Versico Drip Edge for membrane termination. Installation instructions are available from Versico.
4. Metal work by others, when specified and approved by Versico, must be fastened to prevent metal from pulling free or buckling and sealed to prevent moisture from entering the roofing system or building. **Unless supplied by Versico, metal work securement is not included in this specification and is excluded from the Versico Warranty.**
5. **On retrofit projects**, existing counterflashing, edging, expansion joint covers, copings, etc., shall not be reused unless investigated by the specifier to determine its compliance to Versico's current details.

### P. WALKWAYS

Walkways are required at all traffic concentration points (i.e., roof hatches, access doors, rooftop ladders, etc.), and if regular maintenance (once a month or more) is necessary to service rooftop equipment.

#### Walkway types:

1. **TPO Heat Weldable Walkway Rolls** are required when walkway pads are to be specified. The Walkway Rolls are heat welded to the VersiWeld membrane using an Automated Heat Welder or Hand-Held Heat Welder. As an option, the VersiWeld Walkway Roll may be adhered to the membrane surface with Seam Tape and TPO Primer.
2. **Concrete pavers**, when specified, must be loose laid over a slip sheet of membrane or 2 layers of HP Protective Mat and cannot weigh more than 80 pounds per paver for ease of removal.
3. **Versico Interlocking Pavers**, 24" X 24" X 2", weighing approximately 6 pounds per square foot, may be loose laid directly over the membrane. Installation instructions sheets are available from Versico.
4. Pavers are not recommended for use as walkways where roof slopes exceed 2" in 12".
5. Walkways are considered a maintenance item and are excluded from the Versico warranty.
6. Window washing equipment will require special maintenance; runways or window washing tracks must be utilized to prevent damage to membrane or insulation. Such details must be reviewed by Versico to determine reasonable access to the membrane and associated insulation/underlayment components.

ENERGY STAR is a Registered Trademark of Environmental Protection Agency  
LEED is a Trademark of U. S. Green Building Council  
Styrofoam and Deckmate are Trademarks of the DOW Chemical Company.  
Dens-Deck is a Trademark of G-P Gypsum Corporation

This specification represents the applicable information available at the time of its publication. Owners, specifiers and Versico Authorized Roofing Contractors should consult Versico or their Versico Manufacturer's Representative for any information which has subsequently been made available.

Review the appropriate Versico warranty for specific warranty coverage, terms, conditions and limitations.

# VersiWeld Roofing Systems "Attachment I" Products/Coverage Rates

August 2008

## A. Membrane

VersiWeld TPO Membrane meets or exceeds the requirements of ASTM D6878, standard specification for Thermoplastic Polyolefin Based Sheet Roofing. In addition to the physical properties listed below, refer to the VersiWeld Membrane Technical Data Bulletin for Cool Roof Rating Council (CRRC) and LEED™ radiative properties as well as U.S.E.P.A. Toxic Leachate Testing and dynamic puncture resistance.

- VersiWeld 45 or 60-mil thick Reinforced Thermoplastic Polyolefin (TPO) membrane conforms to the following physical properties. Field membrane sheets are available in rolls 12', 10' or 8' wide by 100' long. Perimeter membrane sheets are available in widths of 6' and 5' (used with 12' and 10' wide field sheets) or 4' (used with 8' wide field sheets) by 100' long. VersiWeld Membrane is available in white, gray or tan.

Property (Metric-SI Units)	Test Method	Property of Unaged Sheet 45 or 60-mil		Property After Aging (1) 28 days @ 240° F 45 or 60-mil	
		45-mil	60-mil	45-mil	60-mil
Tolerance on Nominal Thickness, %	ASTM D 751	±10			
Thickness Over Scrim, min, in. (mm)	ASTM D 6878 Optical Method	45-mil 0.015 (0.381) ±10	60-mil 0.020 (0.508) ±10		
Breaking Strength, min, lbf (kN)	ASTM D 751 Grab Method	45-mil 225 (1.0) Min. 320 (1.4) Typical	60-mil 250 (1.1) Min. 360 (1.6) Typical	45-mil 225 (1.0) Min. 320 (1.4) Typical	60-mil 250 (1.1) Min. 360 (1.6) Typical
Elongation at Break of Fabric, min, %	ASTM D 751	25 Typical		25 Typical	
Tearing Strength, min, lbf (N) 8" by 8" specimen	ASTM D 751 B Tongue Tear	55 (245) Min. 130 (578) Typical		55 (245) Min. 130 (578) Typical	
Brittleness Point, max, °F (°C)	ASTM D 2137	-40 (-40) Min. -50 (-46) Typical			
Linear Dimensional Change (shrinkage), %	ASTM D 1204	+/- 0.5 max. -0.2 Typical			
Ozone Resistance, 100 pphm, 168 hours	ASTM D 1149	No Cracks		No Cracks	
Resistance to Water Absorption After 7 days immersion @ 158°F (70°C) Change in mass, max, %	ASTM D 471	4.0 Min. 2.0 Typical			
Resistance to microbial surface growth, rating (1 is very poor, 10 is no growth)	ASTM D 3274 2 yr. S. Florida	9 – 10 Typical			
Field seam strength, lbf/in. (kN/m) Seam tested in peel	ASTM D1876	25 (4.4) Min. 60 (10.5) Typical			
Water vapor permeance, Perms	ASTM E 96	0.10 Max. 0.05 Typical			
Puncture resistance, lbf (N)	FTM 101C Method 2031	45-mil 250 (1.1) Min. 325 (1.4) Typical	60-mil 300(1.3) Min. 350 (1.6) Typical		
Resistance to xenon-arc Weathering (2) Xenon-Arc, 10,080 kJ/m <sup>2</sup> total radiant exposure, Visual condition at 10X	ASTM G 155 0.70 W/m <sup>2</sup> 80°C B.P.T.	No Cracks No loss of breaking or tearing strength			
(1) Aging conditions are 28 days at 240° F (116° C) equivalent to 400 days at 176° F (80° C) for breaking strength, elongation, tearing strength, linear dimensional change, ozone and puncture resistance.					
(2) Approximately equivalent to 8000 hours exposure at 0.35W/m <sup>2</sup> .					

2. VersiWeld Plus 72 or 80-mil thick Reinforced Thermoplastic Polyolefin (TPO) membrane conforms to the following physical properties. Field membrane sheets are available in rolls 12', 10' or 8' wide by 100' long. Perimeter membrane sheets are available in widths of 6' and 5' (used with 12' and 10' wide field sheets) or 4' (used with 8' wide field sheets) by 100' long. VersiWeld Plus Membrane is available in white, gray or tan.

Property (Metric-SI Units)	Test Method	Property of Unaged Sheet 72 or 80-mil		Property After Aging (1) 28 days @ 240° F 72 or 80-mil	
		72-mil	80-mil	72-mil	80-mil
Tolerance on Nominal Thickness, %	ASTM D 751	±10			
Thickness Over Scrim, min, in. (mm)	ASTM D 4637 Optical Method	0.030 (0.762) ±10			
Breaking Strength, min, lbf (kN)	ASTM D 751 Grab Method	350 (1.6) Min. 400 (1.8) Typical	350 (1.6) Min. 425 (1.9) Typical	350 (1.6) Min. 400 (1.8) Typical	350 (1.6) Min. 425 (1.9) Typical
Elongation at Break of Fabric, min, %	ASTM D 751	25 Typical		25 Typical	
Tearing Strength, min, lbf (N) 8" by 8" specimen	ASTM D 751 B Tongue Tear	55 (245) Min. 130 (578) Typical		55 (245) Min. 130 (578) Typical	
Brittleness Point, max, °F (°C)	ASTM D 2137	-40 (-40) Min. -50 (-46) Typical			
Linear Dimensional Change (shrinkage), %	ASTM D 1204	+/- 0.05 max. -0.2 Typical			
Ozone Resistance, 100 pphm, 168 hours	ASTM D 1149	No Cracks		No Cracks	
Resistance to Water Absorption After 7 days immersion @ 158°F (70°C) Change in mass, max, %	ASTM D 471	4.0 Min. 2.0 Typical			
Resistance to microbial surface growth, rating (1 is very poor, 10 is no growth)	ASTM D 3274 2 yr. S. Florida	9 – 10 Typical			
Field seam strength, lbf/in. (kN/m) Seam tested in peel	ASTM D1876	40 (7.0) Min. 60 (10.5) Typical			
Water vapor permeance, Perms	ASTM E 96	0.10 Max. 0.05 Typical			
Puncture resistance, lbf (N)	FTM 101C Method 2031	350 (1.6) Min. 400 (1.8) Typical	400 (1.8) Min. 450 (2.0) Typical		
Resistance to xenon-arc Weathering (2) Xenon-Arc, 10,080 kJ/m <sup>2</sup> total radiant exposure, Visual condition at 10X	ASTM G 155 0.70 W/m <sup>2</sup> 80°C B.P.T.	No Cracks No loss of breaking or tearing strength			
(1) Aging conditions are 28 days at 240° F (116° C) equivalent to 400 days at 176° F (80° C) for breaking strength, elongation, tearing strength, linear dimensional change, ozone and puncture resistance.					
(2) Approximately equivalent to 8000 hours exposure at 0.35W/m <sup>2</sup> .					

- B. **Flashing:** VersiWeld non-reinforced flashing is available in rolls 12" and 24" wide by 50' long. Flashing is used for inside/outside corners and field fabricated pipe flashings when the use of pre-molded or pre-fabricated accessories is not feasible. In addition, 6" wide by 100' long VersiWeld reinforced membrane is available for overlaying fasteners and fastening plates.
- C. **VersiWeld Bonding Adhesive:** A high-strength, synthetic rubber adhesive used for bonding VersiWeld membrane to various surfaces. The adhesive is applied to both the membrane and the substrate at a coverage rate of approximately 60 square feet per gallon per finished surface (includes coverage on both surfaces).
- D. **VersiWeld Low VOC Bonding Adhesive:** An alternate, high-strength, adhesive using a blend of VOC exempt and non-exempt solvent which complies with the state of California Clean Air Act of 1988 (updated in 1997).
- E. **Aqua Base 120 Bonding Adhesive:** A semi pressure-sensitive, water based adhesive used as a two-sided contact adhesive. Coverage rate is 120 square feet per gallon finished surface (applied to membrane and substrate).
- F. **Cut-Edge Sealant:** A white or clear colored sealant used to seal cut edges of reinforced VersiWeld membrane. A coverage rate of approximately 225 - 275 linear feet per squeeze bottle can be achieved when a 1/8" diameter bead is applied.
- G. **Water Cut-Off Mastic:** Used as a mastic to prevent moisture migration at drains, compression terminations and beneath conventional metal edging (at a coverage rate of approximately 10' per tube or 100' per gallon).
- H. **Universal Single-Ply Sealant:** Universal Single-Ply Sealant is white in color and can be used as a termination bar sealant for VersiWeld Fully-Adhered and Mechanically-Attached Roofing Systems.

- I. **Thermoplastic One-Part Sealant:** A one-part, moisture curing, elastomeric polyether sealant used to fill TPO Molded Pourable Sealant Pockets. Packaged in 4, 2-liter foil pouches inside a reusable plastic bucket. 1 pouch will fill 2 TPO Molded Pourable Sealant Pockets.
- J. **Weathered Membrane Cleaner:** Used to prepare membrane that has been exposed to the elements for approximately 7 days prior to heat welding or to remove general construction dirt at an approximate coverage rate of 400 square feet per gallon (one surface).
- K. **Pressure-Sensitive (PS) Coverstrip:** A nominal 40-mil thick non-reinforced TPO membrane laminated to nominal 35-mil thick cured synthetic rubber pressure-sensitive adhesive used in conjunction with TPO Primer to strip in flat metal flanges (i.e., drip edges or rows of fasteners and plates). Available in rolls 6" wide by 100' long in colors of white, gray or tan. Not for use on 20-year Warranty projects.
- L. **TPO PS RUSS:** A nominal 6" and 10" wide, .045" thick reinforced TPO membrane with nominal 3" wide 35-mil thick cured synthetic rubber pressure-sensitive adhesive laminated along one end on 6" wide RUSS and along both ends on 10" wide RUSS. Used in conjunction with TPO Primer. 6" wide RUSS is used as a base membrane securement along walls, curbs, etc.; 10" wide RUSS is used to form perimeter sheets on Mechanically Attached Systems.
- M. **TPO T-Joint Covers:** A 60-mil thick non-reinforced TPO flashing cut into a 4.5" diameter circle used to seal step-offs at seam intersections. Installation is mandatory on all 60, 72, and 80-mil TPO systems and on 45-mil systems where step-offs have not been properly sealed. Packaged in boxes of 100. Available in white, tan or gray.
- N. **TPO Primer:** A solvent-based primer used to prepare the surface of VersiWeld Membrane prior to application of PS Coverstrips, TPO PS RUSS and other PS products.
- O. **VersiWeld Coated Metal :** A 24 gauge, galvanized steel sheet coated with a layer of non-reinforced VersiWeld Flashing. The sheet is cut to the appropriate width and used to fabricate metal drip edges or other roof perimeter edging profiles. VersiWeld Membrane may be heat welded directly to the coated metal. Coated metal is available in sheets 4' X 10' and comes packaged 25 sheets per pallet (also available packaged 10 sheets per pallet on a direct ship basis). Available in white, gray or tan.
- P. **Versico Splice Adhesive:** Used for adhering membrane flashing at tie-ins to VersiGard Black and White EPDM membrane. Applied at a coverage rate of approximately 100 square feet per gallon on each surface.
- Q. **TPO Walkway Rolls:** Consists of recycled VersiWeld Membrane offering superior tear, puncture and weather resistance and designed to protect VersiWeld membrane in those areas exposed to repetitive foot traffic or other hazards. Walkway material may be heat welded to VersiWeld membrane using an automated heat welder or hand held heat welder. Walkway Rolls are 30" wide by 50' long and are nominal 120 mils thick. Available in white only.
- Q. **Pre-Molded Accessories:**
  - 1. **Inside Corners:** A pre-molded corner flashing for inside corners. Available in white, gray or tan; 60-mil thick.
  - 2. **Outside Corners:** A pre-molded corner flashing for outside corners. Available in white, gray or tan; 60-mil thick.
  - 3. **TPO Curb Wrap Corners:** Fabricated flashings are made of 45-mil thick reinforced VersiWeld membrane designed to reduce installation time to flash a curb when compared to conventional methods. Each corner is fabricated with a 6" wide base flange and a 12" overall height. Six sizes are available to fit curbs up to 6' by 6' in size. One curb requires 4 corners for a complete installation. TPO Curb Corners are packaged in boxes of twelve. Custom sizes are available as a special order product requiring lead time.
  - 4. **Molded Pipe Seals:** A pre-molded white, gray or tan pipe flashing used for pipe penetrations. Available for 1" – 6" diameter pipes with clamping rings included.
  - 5. **Split Pipe Seals:** A prefabricated flashing consisting of 45-mil thick reinforced VersiWeld Membrane for pipes 1" – 6" in diameter. A split (cut) and overlapped tab are incorporated to allow the pipe seal to be opened and wrapped around the pipe when it is not possible to pull a standard pipe flashing over a round penetration. Custom sizes are available as a special order product requiring lead time.
  - 6. **TPO Square Tubing Wraps:** Fabricated flashings made of 45-mil thick reinforced VersiWeld membrane for square tubing. A split (cut) and overlap tab are incorporated into these parts to allow the seals to be opened and wrapped around a square penetration. Available for 3", 4", 5" and 6" diameter square tubing.

7. **Molded TPO Sealant Pockets:** A pre-fabricated, interlocking, 2-piece, injection molded, flexible pocket with a rigid polypropylene vertical wall and pre-formed deck flanges. Used in conjunction with Thermoplastic One-Part Pourable Sealer for waterproofing pipe clusters or other odd shaped penetrations. Available in white, gray or tan. Forms a 7-1/2" by 6" oval when completed.
8. **Pre-Fabricated Sealant Pockets:** A two-piece, pre-fabricated sealant pocket that utilizes reinforced TPO membrane and coated metal to form a rigid, oversized sealant pocket with a weldable horizontal deck flange. Available in 12" (total volume of 1.87 gallons), 16" (total volume of 2.77 gallons) and 20" (total volume of 3.81 gallons). Packaged 2 per carton and available in white only. Refer to the applicable Technical Data Bulletin for dimensions and installation instructions.
9. **Sealant Pocket Extension Legs:** Designed for use with the TPO Molded Sealant Pocket and the Pre-Fabricated Sealant Pocket to extend the length in increments of 10". Fabricated from 45-mil thick reinforced TPO membrane and TPO coated metal. Can be used full length, cut to size for customized lengths or welded to each other for extra long applications. Packaged 10 legs per carton and available in white only.

#### R. Fasteners:

1. **HPVX Fastener:** A heavy duty #15 threaded fastener with a Phillips head used for membrane and insulation attachment over steel, wood plank or minimum 15/32" thick plywood.
2. **HPV-XL Fastener:** An oversized diameter #21 (.315") steel threaded fastener used in conjunction with HPV-XL Plates for membrane securement into minimum 22 gauge steel or wood decks.
3. **HP Fastener:** A threaded "E-Coat" square head fastener for insulation attachment only. Used into steel, wood plank, minimum 15/32" thick plywood or minimum 7/16" thick oriented strand board.
4. **Pre-Assembled ASAP Fasteners:** A #3 Phillips head fastener and pre-assembled 3" diameter Plastic Insulation Plate used for insulation attachment only into steel or wood decks.
5. **Insul-Tite Insulation Fasteners:** A threaded #12 Phillips head fastener used with 3" diameter insulation fastening plates for insulation attachment only into steel or wood decks.
6. **CD-10 Fastener:** A hammer-driven, non-threaded E-Coat fastener for use with structural concrete decks rated 3,000 psi or greater.
7. **MP 14-10 Concrete Fasteners:** A #14 threaded fastener used for minimum 3,000 psi concrete decks.
8. **NTB Fastener:** A non-penetrating, plastic fastener and corresponding plate used with lightweight substrates such as cementitious wood fiber and gypsum decks. A 2" steel plate is available for membrane attachment or insulation securement on Mechanically Attached Systems. For Fully-Adhered Systems, a 3" steel plate is available for insulation attachment.
9. **Lite-Deck Fastener:** A oversized diameter fastener and associated 3" Lite-Deck Metal Plate for use on Fully-Adhered Roofing Systems to attach insulation to gypsum decks.

#### S. Fastening Plates:

1. **HPVX Plates:** A 2-3/8" diameter metal barbed fastening plate used with Versico HPVX, CD-10 or MP 14-10 Fasteners for membrane securement. This plate can be used for insulation securement.
2. **HPV-XL Plates:** A 2-3/8" diameter metal barbed fastening plate with an oversized hole for use with Versico HPV-XL Fasteners for membrane securement.
3. **Seam Fastening Plates:** A 2" diameter metal plate used for insulation attachment on Mechanically Attached Roofing Systems or membrane securement on Fully-Adhered Roofing Systems in conjunction with the appropriate Versico Fastener.
4. **Insulation Fastening Plates:** A nominal 3" diameter metal plate used for insulation attachment in conjunction with the appropriate Versico Fastener.

- T. **Versico Seam Probe:** A hand tool used to check the integrity of heat welded seams on heat welded roofing systems. The probe has a heat-treated tip and the handle is tapped to fit standard threaded extension handles allowing the tool to be used from a standing position.

# VersiWeld Roofing Systems "Attachment II"

## Withdrawal Resistance Criteria

August 2008

A. The following chart indicates the appropriate Versico Fastener for use with the referenced roof deck and includes the **minimum pullout** and fastener penetration requirements for membrane/insulation securement on Mechanically Attached Roofing Systems and for insulation attachment on Fully-Adhered Roofing Systems.

Deck Type	Minimum Pullout	Approved Fasteners & Plates for membrane securement on Mechanically Attached Systems (1) and approved fasteners for insulation attachment on Fully Adhered Systems (5)	Minimum Penetration
Steel, 22 gauge or heavier (2)	500 pounds (Mechanically Attached)	HPVX Fasteners & HPVX Plates or HPV-XL Fasteners & HPV-XL Plates	3/4"
	360 pounds (Fully-Adhered)	HPVX, HPV, ASAP or Insul-Tite Fasteners )	
Steel, less than 22 gauge (3)	300 pounds (Fully-Adhered only) (3)	HPVX, HPV, ASAP or Insul-Tite Fasteners	3/4"
Lightweight Insulating Concrete over Steel (4)	360 pounds	HPVX Fasteners & HPVX Plates (Mechanically Attached)	3/4"
		HPVX, HPV, ASAP or Insul-Tite Fasteners (Fully Adhered)	
Structural Concrete, rated 3,000 psi or greater	800 pounds	CD-10 or MP 14-10 Fasteners and HPVX Plates	1"
Wood Planks and Plywood, min. 15/32" thick APA Grade CDX	360 pounds	HPVX Fasteners & HPVX Plates or HPV-XL Fasteners and HPV-XL Plates (Mechanically Attached)	1" (Max. 1-1/2" on wood planks)
		HPVX, HPV, ASAP or Insul-Tite Fasteners (Fully Adhered)	
Oriented Strand Board (OSB), Min. 7/16" thick (7) APA Rated non-veneer	360 pounds (Mechanically Attached)	HPVX Fasteners & HPVX Plates or HPV-XL Fasteners and HPV-XL Plates	1"
	250 pounds (Fully-Adhered)	HPVX or HPV Fasteners	1"
Cementitious Wood Fiber and Gypsum	300 pounds	NTB Fastener with 2" diameter plates	1-1/2"

**Notes:**

1. For membrane fastening density requirements, refer to Attachment III at the end of this section.
2. Mechanically Attached Roofing Systems are not permitted over corrugated steel decks, regardless of gauge.
3. Mechanically Attached Roofing Systems are not permitted over steel decks less than 22 gauge unless used in conjunction with lightweight insulating concrete and acceptable pullouts are obtained using HPVX Fasteners.
4. Fasteners are installed through the lightweight insulating concrete into the steel deck below.
5. For Fully Adhered systems, only 3" diameter insulation fastening plates can be used for insulation attachment.

B. Withdrawal resistance testing may be conducted by an independent laboratory, fastener manufacturer or a representative of Versico on the following roof decks. The results of the pullout tests must be documented and submitted to Versico when the pullout results are less than listed above.

1. Cementitious wood fiber or gypsum
2. Lightweight insulating concrete over steel decks lighter than 22 gauge
3. Minimum 7/16" thick oriented strand board (OSB)
4. For 22 gauge steel, wood plank, plywood or structural concrete decks, a withdrawal resistance test is strongly recommended.

5. **On retrofit projects**, a core cutter shall be used to remove existing roofing material prior to conducting the withdrawal resistance test (even if the existing roofing membrane is specified to remain). Existing roofing materials will contribute to a higher, misleading pullout value.
6. The following minimum trial fastener samples must be installed and tested over the roof deck at each level:
  - a. For each roof level of 5,000 square feet or less, conduct a minimum of 3 pullouts.
  - b. For each roof level greater than 5,000 square feet and less than 20,000 square feet, conduct a minimum of 10 pullouts.
  - c. For each roof level greater than 20,000 square feet and less than 50,000 square feet, conduct a minimum of 15 pullouts.
  - d. For each roof level greater than 50,000 square feet and less than 100,000 square feet, conduct a minimum of 20 pullouts.
  - e. For each roof level greater than 100,000 square feet, conduct a minimum of 1 pullout per each 5,000 square feet.

**Note:** On projects with multiple roof levels, when pullouts are conducted on the main roof level, smaller canopies, overhangs, penthouses, etc., of 1,000 square feet or less will not require pullout tests providing these areas consist of the same decking material as the main roof level.
7. The trial fastener installations must be tested in various locations of the roof deck including roof corners and perimeters (areas parallel to the edge of the roof with a width which is 0.4 times the building height). Designate the test locations on a roof plan and include with the submittals to Versico when requested.

# VersiWeld Mechanically Attached Roofing Systems

## "Attachment III"

### Membrane Securement Criteria

December 2008

A. For designation of wind zones listed on the following chart, refer to Basic Wind Speed Map in this Attachment. If Factory Mutual approvals are specified, refer to Versico's VersiWeld Code Approval Guide for fastener/plate options and additional membrane securement requirements, which may be applicable.

To determine appropriate securement requirements, identify project wind zone from the map (at the end of this section) and select the chart based on project deck type. The building height is then used to determine membrane securement requirements for the project.

Wind Zone	Deck Type (1)	Building Height	Field Membrane Width	Fastening Density (Field & Perimeter Sheets)
<b>Zone 1 Up to 100 MPH</b>	Steel, Lightweight Insulating Concrete over Steel, Structural Concrete, Wood Planks	Max. 40'	12'	12" O.C.
	Steel, Lightweight Insulating Concrete over Steel, Structural Concrete, Plywood, Wood Planks or Oriented Strand Board (3)	Max. 75'	10'	12" O.C.
	Gypsum and Cementitious Wood Fiber	Max. 75'	10' 8'	9" O.C. 12" O.C.
<b>Zone 2 100-119 MPH</b>	Steel, Lightweight Insulating Concrete over Steel, Wood Planks (New or Tearoff)	Max. 40'	12'	6" O.C.
	Steel, Lightweight Insulating Concrete over Steel, Wood Planks (Reroof/No Tearoff)	Max. 40'	12'	12" O.C.
	Steel, Lightweight Insulating Concrete over Steel, Plywood, Wood Planks or Oriented Strand Board (3)	Max. 50'	10'	12" O.C.
	Structural Concrete	Max. 40'	12'	12" O.C.
		Max. 75'	10'	12" O.C.
	Gypsum and Cementitious Wood Fiber	Max. 50'	10' 8'	9" O.C. 12" O.C.
<b>Zone 3 120-129MPH (4)</b>		Steel, Lightweight Insulating Concrete over Steel	Max. 75'	10' 8'
	Max. 50'		10'	12" O.C.
	Plywood, Wood Planks (2), Oriented Strand Board (3), Gypsum and Cementitious Wood Fiber	Max. 50'	8'	9" O.C.
<b>Zone 4 130 MPH or Greater</b>	Steel or Lightweight Insulating Concrete over Steel	Max. 75'	10'	6" O.C. **
			8'	9" O.C. *
	Structural Concrete	Max. 50'	8'	12" O.C.
	Plywood, Wood Planks (2), Oriented Strand Board, Gypsum or Cementitious Wood Fiber	<b>NOT ACCEPTABLE (2)</b>		

\* If HPV-XL Fasteners/HPV-XL Plates are used, fastener spacing may be 12" on center.  
 \*\* If HPV-XL Fasteners/HPV-XL Plates are used, fastener spacing may be 9" on center.

Notes:

1. Refer to "Attachment II, for minimum roof deck/pullout requirements and the required Versico Fastener.
2. On plywood or wood plank decks, if pullout tests exceed 425 pounds per fastener, the membrane securement requirements for steel decks may be followed providing the pullout tests are submitted to Versico for approval.
3. On oriented strand board decks less than 5/8" in thickness, HPV Fasteners are required for membrane securement. For oriented strand board decks 5/8" thick or greater, HPVX Fasteners may be used for membrane securement if a minimum pullout value of 360 pounds can be achieved.
4. Those areas located between wind zone contours of 120-129 MPH within 20 miles of the coastline shall be considered as a Zone 4 Wind Zone.

- B. **Perimeter sheets are required along the roof perimeter**, which is defined as all edges of each roof section. Where multi-level roofs meet at a common wall, the adjacent edge of the upper roof is treated as a roof perimeter if the difference in height is greater than 3'. Perimeter sheets are not required at the base of the wall at the lower level. Refer to Detail VWMA-2 in Part II "Application" for further information.

The number of perimeter sheets required is dependant on project wind zone and building height as identified in the chart below. **At roof ridges** (when slopes exceed 3" to the horizontal foot), one perimeter membrane sheet, centered approximately over the roof ridge is required.

1. **When using 12' and 10' wide field sheets, 6' or 5' wide perimeter sheets** are utilized along roof edges
2. **When using 8' wide field sheets, 4' wide perimeter sheets** are utilized along roof edges.
3. As an option to the use of perimeter sheets, 10" wide TPO PS RUSS can be used beneath the field sheets to create perimeter sheets. Refer to the VersiWeld Mechanically Attached Application Section, Part II, for specific requirements.

Wind Zone	Building Height	# of Perimeter Sheets Required (Note 1)
Up to 100 mph	Up to 45' (Note 2)	1
	46 to 100'	2
100 to 110	Up to 45'	1
	46 to 100'	3
110 to 120	Up to 45'	2
	46 to 100'	3
120 mph or Greater	Up to 45'	3
	46 to 100'	4

**Notes:**

1. Fastener spacing for perimeter membrane sheets is equivalent to the fastener spacing for field sheets.
2. Two perimeter sheets required when 12' sheets are fastened 12" o.c.

C. **Buildings With Large Openings and Overhangs**

When any wall contains major openings with a combined area, which exceeds 10% of the total wall area on which the openings are located, four (4) perimeter sheets (centered over the opening) must be specified as shown.

1. When using 12' or 10' wide field membrane sheets, 6' or 5' wide perimeter sheets are utilized. When using 8' wide field sheets, 4' wide perimeter sheets are utilized. 10" wide PS RUSS can also be used beneath the field sheets to create perimeter sheets.
2. As an option to the above perimeter securement, an adhered membrane section may be used in lieu of the mechanically attached membrane at large openings in accordance with the Versico Specification for VersiWeld Fully-Adhered Systems.

**Large Openings**

Note: Fastening plates are required at the end laps of the Perimeter membrane sheets on both sides of the opened area

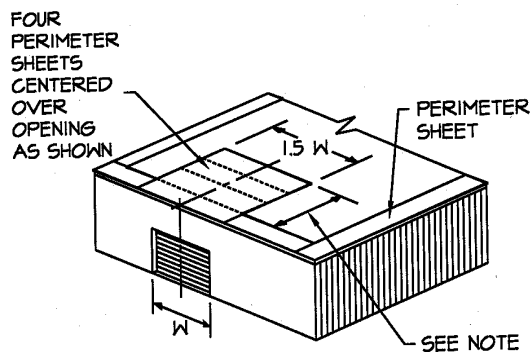

**Overhangs**

The membrane must be specified with perimeter sheets installed over the entire overhang area extending onto the main roof deck when at the same level.

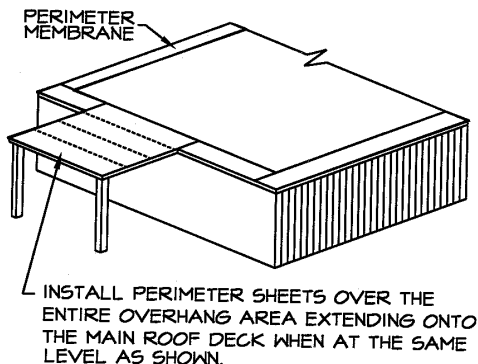

# Basic Wind Speed Map

(Based on ASCE 7-02)

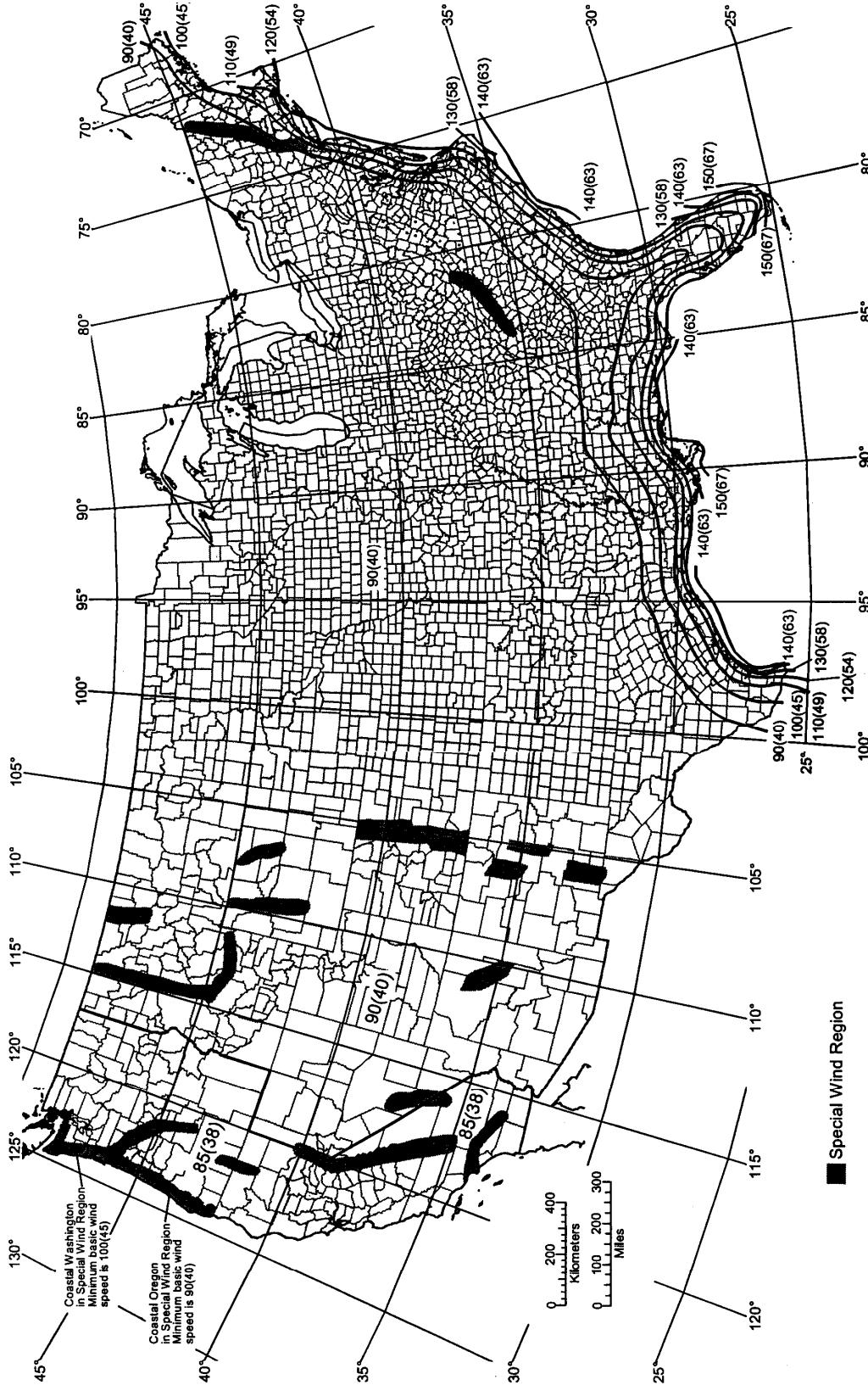

- |        |                      |
|--------|----------------------|
| Zone 1 | – Up to 100 MPH      |
| Zone 2 | – 100 - 119 MPH      |
| Zone 3 | – 120 - 129 MPH      |
| Zone 4 | – 130 MPH or Greater |

- Notes:
1. Values are nominal design 3-second gust wind speeds in miles per hour (m/s) at 33ft (10m) above ground for Exposure C category.
  2. Linear interpolation between wind contours is appropriate.
  3. Islands and coastal areas outside the last contour shall use the last wind speed contour of the coastal area.
  4. Mountainous terrain, gorges, ocean promontories, and special wind regions shall be examined for unusual wind conditions. Seek 50-yr MRI wind speed values from local building officials. As a minimum, increase the wind speed values by 10% except where minimum wind speed values are noted in Washington and Oregon

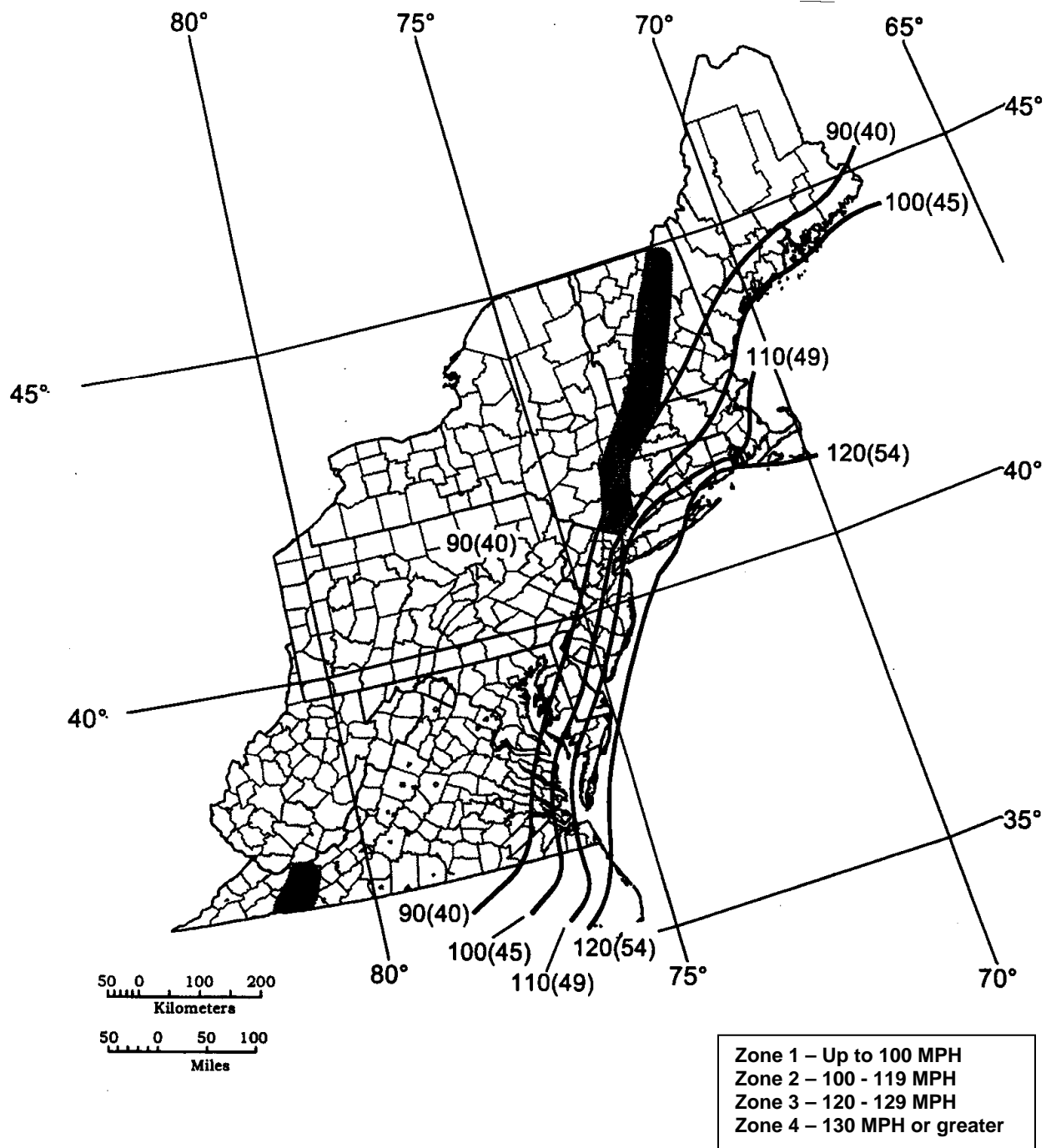

**Notes:**

1. Values are nominal design 3-second gust wind speeds in miles per hour (m/s) at 33' above Ground for Exposure C category.
2. Linear interpolation between wind contours is appropriate.
3. Islands and coastal areas outside the last contour shall use the wind speed contour of the coastal area.
4. Mountainous terrain, gorges, ocean promontories, and special wind regions shall be examined for unusual wind conditions, Seek 50 year MRI wind speed values from local building officials. As a minimum, increase the wind speed values by 10%.

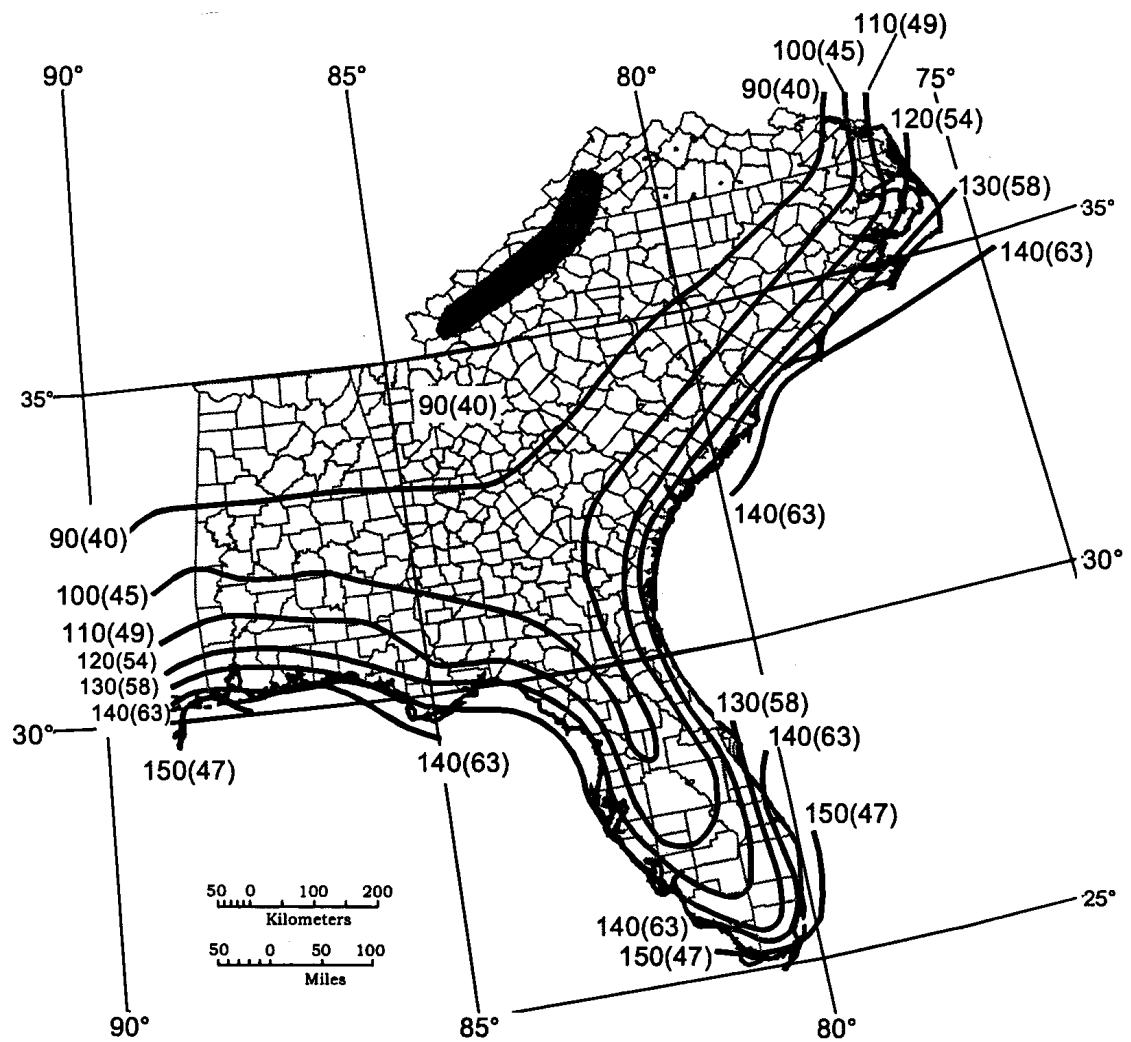

■ Special Wind Region

<p>Zone 1 – Up to 100 MPH          Zone 2 – 100 - 119 MPH          Zone 3 – 120 - 129 MPH          Zone 4 – 130 MPH or greater</p>
--

**Notes:**

1. Values are nominal design 3-second gust wind speeds in miles per hour (m/s) at 33' above Ground for Exposure C category.
2. Linear interpolation between wind contours is appropriate.
3. Islands and coastal areas outside the last contour shall use the wind speed contour of the coastal area.
4. Mountainous terrain, gorges, ocean promontories, and special wind regions shall be examined for unusual wind conditions, Seek 50 year MRI wind speed values from local building officials. As a minimum, increase the wind speed values by 10%.

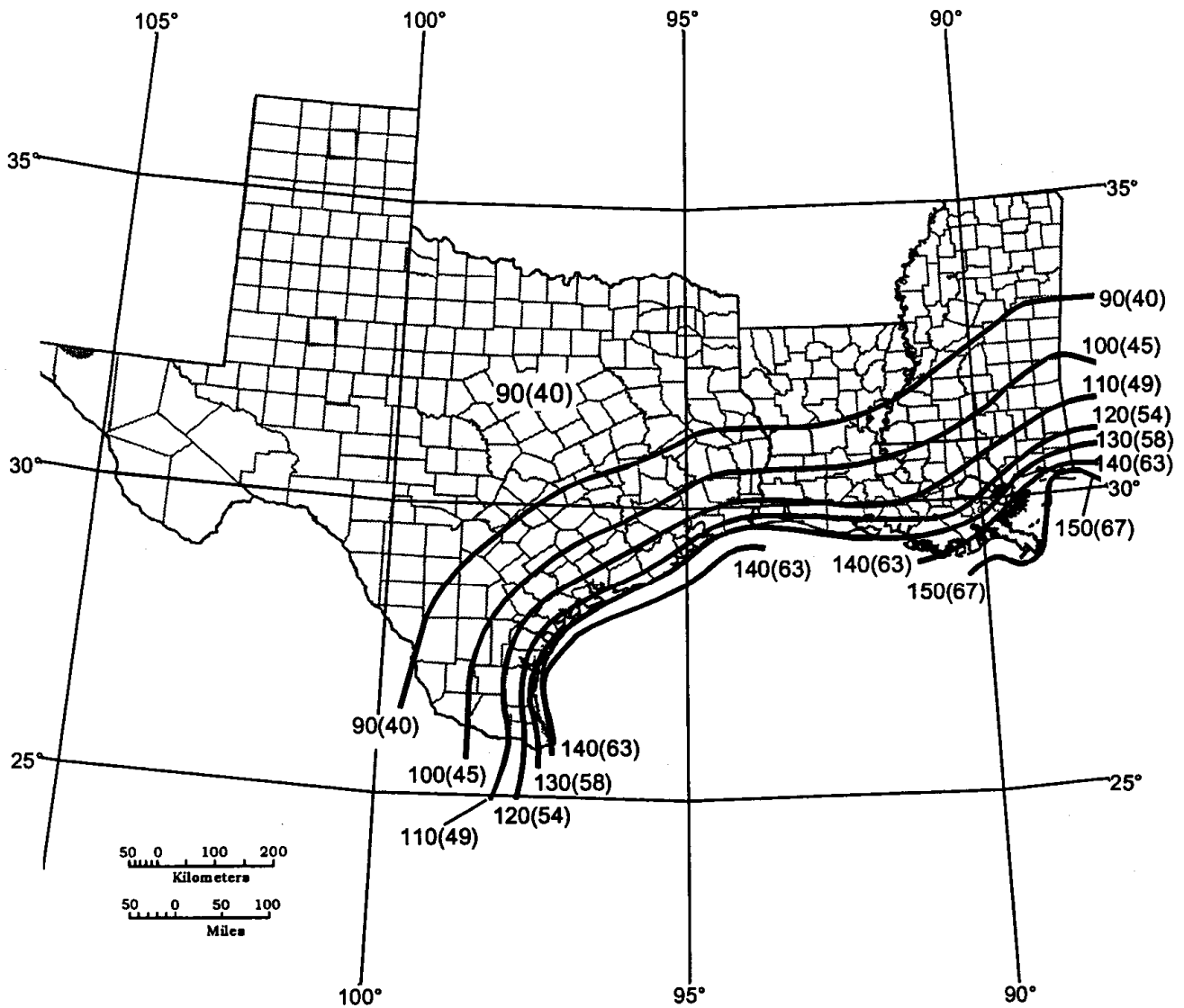

Zone 1 – Up to 100 MPH
Zone 2 – 100 - 119 MPH
Zone 3 – 120 - 129 MPH
Zone 4 – 130 MPH or greater

■ Special Wind Region

**Notes:**

1. Values are nominal design 3-second gust wind speeds in miles per hour (m/s) at 33' above Ground for Exposure C category.
2. Linear interpolation between wind contours is appropriate.
3. Islands and coastal areas outside the last contour shall use the wind speed contour of the coastal area.
4. Mountainous terrain, gorges, ocean promontories, and special wind regions shall be examined for unusual wind conditions, Seek 50 year MRI wind speed values from local building officials. As a minimum, increase the wind speed values by 10%.

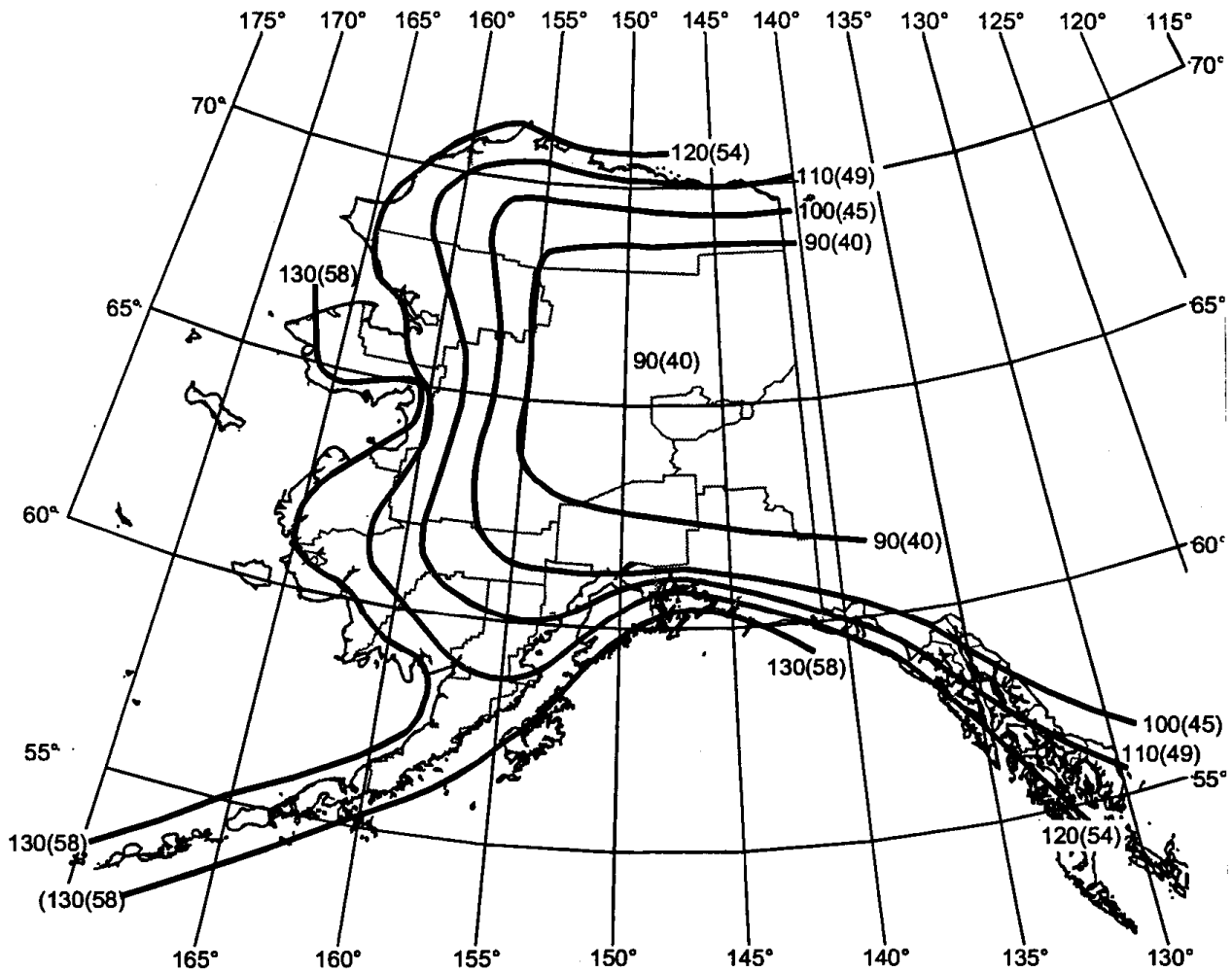

<b>Zone 1 – Up to 100 MPH</b> <b>Zone 2 – 100 - 119 MPH</b> <b>Zone 3 – 120 - 129 MPH</b> <b>Zone 4 – 130 MPH or greater</b>
---

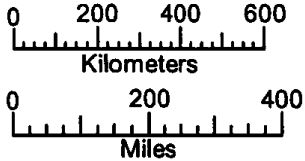

Notes:

1. Values are nominal design 3-second gust wind speeds in miles per hour (m/s) at 33' above Ground for Exposure C category.
2. Linear interpolation between wind contours is appropriate.
3. Islands and coastal areas outside the last contour shall use the wind speed contour of the coastal area.
4. Mountainous terrain, gorges, ocean promontories, and special wind regions shall be examined for unusual wind conditions, Seek 50 year MRI wind speed values from local building officials. As a minimum, increase the wind speed values by 10%.

# VersiWeld Roofing Systems "Attachment IV"

## 10 or 15-Year Extended Warranty Wind Speed Coverage Design Criteria

August 2008

Information contained in this Attachment is intended as a guideline for specifiers when a 10 or 15-year Total System Warranty is specified with wind speed coverage greater than 55 mph. At the contractor's or specifier's discretion, projects may be forwarded to the Versico System Design and Review Group for evaluation prior to installation.

### A. General Restrictions/Applicability

1. For Mechanically Attached Roofing Systems, building height shall not exceed 75'. Fully-Adhered applications are limited to a building height of 100'.
2. Recover projects (where the old roof remains in place) are acceptable up to 80 mph wind speed coverage. When 90 mph wind speed coverage is desired, any existing roof material must be totally removed unless a moisture scan (nuclear or thermal) is performed by an independent laboratory and submitted to Versico for review. For all projects, wet and damaged roofing material must be removed.
3. Special attention should be focused on perimeter wood nailers where Versico Metal Edging will be secured. Fastening criteria published by Factory Mutual Loss Prevention Data Sheet 1-49 should be referenced.
4. When a warranty wind speed of 80 mph or greater is desired, air infiltration must be prevented along the roof edge by adhering the membrane over the perimeter wood nailers and down the outside face of the building. Refer to the chart below for acceptable metal edging.
5. When mechanical securement is specified for insulation attachment, Versico Fasteners must be used, regardless of the warranty specified.

### B. Mechanically Attached Roofing Systems - Design Criteria

Acceptable decks shall consist of 22 gauge steel, structural concrete (3,000 psi or greater), wood, gypsum or fibrous cement.

1. Plywood (less than 3/4" thick), OSB (minimum 7/16" thick), gypsum and fibrous cement decks are limited to a maximum peak gust wind speed coverage of 72 mph.
2. Lightweight insulating concrete over steel decks lighter than 22 gauge can be accepted for projects up to maximum 72 mph wind speed coverage when pullouts into the steel deck exceed 360 pounds with Versico HPVX Fasteners.

Peak Gust Wind Speed	Membrane Thickness	Deck Type	Membrane Securement (1)		Metal Edging
			Min. # of Perimeter Sheets (2)	Width of Field Sheets/Fastening	
72 mph	VersiWeld 45-mil Reinforced	Structural Concrete	2	10'/12" o.c.	Versico or others
		All Others	2	8'/12" o.c. or 10'/9" o.c. *	
80 mph	VersiWeld 45-mil Reinforced	Structural Concrete	4	10'/12" o.c.	Versico or others
		Steel, Wood	3	8'/12" o.c. or 10'/9" o.c. *	
90 mph	VersiWeld 45-mil Reinforced	Structural Concrete	3	8'/12" o.c. or 10'/9" o.c.	Versico Drip Edge (3), VersiTrim (3) VersiTrim 200 (3) or VersiTrim 2000 or 3000
		Steel, Wood(4)	3	10'/6" o.c.	
100 mph	VersiWeld 60, 72 or 80-mil Reinforced	Structural Concrete	2/6" o.c.	8'/12" o.c. or 10'/9" o.c.	Versico Drip Edge (3), VersiTrim (3) VersiTrim 200 (3) or VersiTrim 2000 or 3000
		Steel or Wood (4)	1st 2 sheets 6" o.c.	6'/9" o.c. *	

Notes:

- (1) Versico HPVX Fasteners (steel and wood decks) and CD-10 or MP 14-10 Concrete Fasteners (concrete decks) must be used with HPVX Plates for membrane securement unless otherwise noted.
  - (2) Fastener spacing for perimeter sheets shall be the same as for field sheets unless noted otherwise. Additional perimeter sheets may be required as identified in Versico's most current VersiWeld Mechanically Attached Roofing System Specifications.
  - (3) Versico HPV or HPVX Fasteners must be used to secure Versico Drip Edge or VersiTrim/ VersiTrim 200 Metal Fascia to wood nailers.
  - (4) Minimum 3/4" thick plywood or minimum 1-1/2 " thick wood planks only.
- \* If HPV-XL Fasteners/HPV-XL Plates are used, fastener spacing may be 12" on center into steel decks.

C. Fully-Adhered Roofing Systems - Design Criteria

1. **Gypsum and Fibrous Cement decks** are acceptable for **maximum 72 mph wind speed coverage** when a minimum pullout of 300 pounds per fastener is achieved with Versico NTB Fasteners. Minimum fastening density shall be 1 per 2 square feet.
2. Plywood decks (less than 3/4") and oriented strand board (minimum 7/16" thick) decks can be accepted for maximum 80 mph wind speed coverage.
3. Lightweight insulating concrete over steel decks can be accepted for projects up to maximum 90 mph wind speed coverage when pullouts into the steel deck exceed 360 pounds with Versico HPVX Fasteners.
4. FAST Adhesive may be used for insulation attachment in lieu of Versico Fasteners.

Peak Gust Wind Speed	Membrane Underlayment	Fastening Density	Corner and or Perimeter Insulation Fastening Enhancement	Metal Edging
72 or 80 mph	1/4" Dens-Deck® Prime	12 fasteners per 4' x 8' board	50% increase at 12' x 12' corners	Versico Drip Edge, VersiTrim, VersiTrim 200 or VersiTrim 1000 may be fastened with ring shank nails staggered 4" on center. Versico HP or HPVX Fasteners may also be used fastened 12" on center.
	1/2" HP Recovery Board	1 fastener per 2 square feet	None	
	Min. 1.2" Polyisocyanurate	1 fastener per 2 square feet		
	Min. 1-1/2" Polyisocyanurate	1 fastener per 2.9 square feet (11 fasteners per 4' x 8' board) (4)	None	
	Min. 2" Polyisocyanurate	1 fastener per 4 square feet (4)		
90 mph	1/2" Dens-Deck Prime	12 fasteners per 4' x 8' board	50% increase at 12' x 12' corners	Versico Drip Edge (1) VersiTrim™ (1) (3), VersiTrim 200 (1) (3) or VersiTrim 1000, 2000 or 3000
	1/2" HP Recovery Board	1 fastener per 2 square feet		
	Min. 1.5" 25 psi Polyisocyanurate - <b>for max. 10 year warranty</b>	1 fastener per 2 square feet		
100 mph	7/16" Oriented Strand Board (2) over approved Versico Insulation	17 fasteners per 4' x 8' Board	None	Drip Edge (1), VersiTrim (1) (3), VersiTrim 200 (1) (3) or VersiTrim 2000 or 3000
	5/8" Dens-Deck Prime	1 fastener per 2 square feet		
120 mph	7/16" Oriented Strand Board (2) over approved Versico Insulation	17 fasteners per 4' x 8' Board	50% increase at 12' x 12' Corners	VersiTrim 2000 or 3000
	5/8" Dens-Deck Prime	24 fasteners per 4' x 8' board		

Notes:

- (1) Versico HPV or HPVX Fasteners must be used to secure Versico Drip Edge or VersiTrim/VersiTrim 200 Metal Fascia to perimeter wood nailers.
- (2) Oriented Strand Board (OSB) must be APA trademarked with Exposure 1 Durability Rating. OSB cannot be installed directly over concrete roof decks or existing roofing material.
- (3) Membrane securement is required at the base of the VersiTrim/VersiTrim 200 waterdam.
- (4) For Gypsum and Fibrous Cement decks, fastening density must be 1 fastener per 2 square feet and a maximum 72 mph warranty coverage is available. Increase in fasteners at corners not required on Gypsum or Fibrous Cement decks

# VersiWeld Roofing Systems "Attachment V"

## 20-Year Warranty - Design Enhancements

December 2008

Information contained in this Attachment outlines necessary enhancements required for projects where a 20-year Total System Warranty is specified. At the contractor's or specifier's discretion, projects may be forwarded to Versico for evaluation prior to installation or bid.

### A. Design Criteria

1. Minimum 60-mil thick VersiWeld Reinforced Membrane is required. All "T" joints must be overlaid with VersiWeld "T" Joint Covers or VersiWeld Non-Reinforced Flashing heat welded on all sides.
2. For Mechanically Attached Roofing Systems, building height shall not exceed 50'. Fully-Adhered applications are limited to a building height of 100'. Projects with a building height greater than those listed may be submitted for Versico's review.
3. A minimum slope of 1/4" per horizontal foot preferred; however, 1/8" slope with sufficient number of drains and crickets/saddles may be accepted.
4. All products specified for this roofing assembly must be products manufactured or marketed by Versico.
5. On recover projects where the existing roofing material is to be left in place, all wet roofing material must be totally removed. A thorough roof investigation utilizing moisture scanning devices is strongly recommended.
6. Shop drawings must include all pertaining details.

### B. Acceptable Deck Types - Refer to "Attachment II" for minimum pullout criteria.

1. Steel (22 gauge or heavier)
2. Structural Concrete (minimum 3,000 psi)
3. Plywood (minimum 15/32" thick).
4. Wood Planks (minimum 1-1/2" thick).
5. Fibrous Cement and Gypsum (Fully-Adhered Roofing Systems only with maximum warranty wind speed of 72 mph)

### C. Mechanically Attached Assemblies (maximum 50' in height)

#### 1. Acceptable Insulation/Underlayment

- a. Versico Polyisocyanurate (standard compressive strength).
- b. Versico Recovery Board or Dens-Deck/Dens-Deck Prime **over any Versico insulation.**

**Note:** Versico Recovery Board or Dens-Deck may only be use on top of Versico insulation. Their direct use over any existing roofing membrane or roof deck is not permitted.

- c. Versico FR Base Sheet may be approved to meet certain fire codes over combustible roof decks.
- d. **Insulation Securement** - Versico Recovery Board, Dens-Deck/Dens-Deck Prime or Polyisocyanurate Insulation fastened with 6 fasteners/plates per 4' x 8' board (1 per 5.3 square feet). When 4' x 4' boards are used 4 fasteners/plates are required (1 per 4 square feet).

#### 2. Membrane Fastening Requirements

- a. On steel and wood decks, HPVX Fasteners/HPVX Plates or HPV-XL Fasteners/HPV-XL must be used. Assemblies where the fastener length is expected to exceed 6" in length, must be submitted to Versico to determine a suitable fastening density.
- b. On structural concrete decks, CD-10 or MP 14-10 Concrete Fasteners shall be used with HPVX Plates.

- c. **Field Membrane Securement:**
- 1) On steel or wood plank decks, 8' wide field sheets shall be fastened 12" o.c. or 10' wide field sheets fastened 6" o.c. with HPVX Fasteners/HPVX Plates.
  - 2) On steel decks, 10' wide field sheets can be fastened 12" o.c. with HPV-XL Fasteners and HPV- XL Plates.
  - 3) On 15/32" plywood decks, 8' wide field sheets shall be fastened 9" o.c with HPVX Fasteners/HPVX Plates.
  - 4) On structural concrete decks, 10' wide field sheets shall be fastened 12" o.c. with CD-10 or MP 14-10 Concrete Fasteners with HPVX Plates.
- d. **Perimeter Membrane Securement:**
- 1) 4' wide perimeter sheets shall be used with 8' wide field sheets; 6' or 5' wide perimeter sheets are used with 10' field sheets.

Wind Zone	Building Height	# of Perimeter Sheets Required (Note 1)
Up to 100 mph	Up to 45' (Note 2)	1
	46 to 100'	2
100 to 110	Up to 45'	1
	46 to 100'	3
110 to 120	Up to 45'	2
	46 to 100'	3
120 mph or Greater	Up to 45'	3
	46 to 100'	4

**Note:**  
Fastener spacing for perimeter membrane sheets is equivalent to the fastener spacing for field sheets.

**D. Fully-Adhered Roofing Assemblies (maximum 100' in height)**

1. **Acceptable Insulation/Underlayment**
  - a. Minimum 1-1/2" Versico Polyisocyanurate (standard compressive strength). Minimum 1" thickness acceptable for use on reroofing projects.
  - b. Versico Recovery Board or Dens-Deck Prime over any Versico Insulation

**Note:** Versico Recovery Board or Dens-Deck Prime may only be use on top of Versico insulation. Their direct use over any existing roofing membrane or roof deck is not permitted.

- c. Minimum 7/16" OSB over any Versico Insulation or OSB/Polyiso Composite.

2. **Warranty Wind Speed (Maximum Peak Gusts)**

Wind speed coverage available will vary depending on deck type, fastening density and the type of membrane underlayment utilized. Paragraph D.3, Insulation/Underlayment Attachment on the following page, should be referenced to determine the approved fastening pattern for the desired assembly.

**Note:** Projects with cementitious wood fiber or gypsum decks are limited to a maximum wind speed coverage of 72 mph regardless of the membrane underlayment utilized.

- a. **55 mph** – Adhered to standard Versico Polyisocyanurate
- b. **72 mph** – Adhered to 25 psi Versico Polyisocyanurate
- c. **80 mph** – Adhered to Versico Recovery Board or 1/4" thick Dens-Deck Prime (installed over approved Versico Insulation).
- d. **90 mph** – Adhered to 1/2" Dens-Deck Prime (installed over approved Versico Insulation).
- e. **100 mph** – Adhered to 7/16" OSB or 5/8" thick Dens-Deck Prime (installed over approved Versico Insulation).
- f. **120 mph** – Adhered to 7/16" OSB or 5/8" thick Dens-Deck Prime (installed over approved Versico Insulation).

### 3. Insulation/Underlayment Attachment

Outlined below are different fastening patterns for insulations and underlayments suitable for the various wind speed coverages available. In addition to mechanical securement, FAST Adhesive may be used to attach all insulation listed in this attachment to the structural deck. When OSB is used as a separate membrane underlayment, it must be mechanically attached. Refer to Paragraph D.3.i for other options.

- a. Minimum **2" thick Versico Polyisocyanurate** shall be fastened 1 per 4 square feet (8 fasteners per 4' x 8' board) except on fibrous cement and gypsum decks where a fastening density of 1 fastener per 2 square feet is required.
- b. Minimum **1-1/2" thick Versico Polyisocyanurate** shall be fastened 1 per 2.9 square feet (11 fasteners per 4' x 8' board) except on fibrous cement and gypsum decks where a heavier density of 1 fastener per 2 square feet is required.
- c. **Versico Polyisocyanurate less than 1-1/2" thick** (reroofing projects) shall be fastened 1 per 2 square feet.
- d. **1/2" thick HP Recovery Board** shall be fastened 1 per 2 square feet.
- e. **1/4" thick Dens-Deck Prime** shall be fastened a minimum of 12 fasteners/plates per 4' x 8' board. Fastening density shall be increase by 50% in the perimeter area (minimum 12') in order to achieve a maximum peak gust wind speed coverage on the warranty of **80 mph**.
- f. **1/2" thick Dens-Deck Prime** shall be fastened a minimum of 12 fasteners/plates per 4' x 8' board. Fastening density shall be increased by 50% in the perimeter area (minimum 12') in order to achieve a maximum peak gust wind speed coverage on the warranty of **90 mph**.
- g. **5/8" thick Dens-Deck Prime** shall be fastened at a rate of 1 fastener/plate per 2 square feet to achieve a maximum **peak gust wind speed** coverage on the warranty of **100 mph**.
- h. **5/8" thick Dens-Deck Prime** shall be fastened a minimum of 24 fasteners/plates per 4' x 8' board. Fastening density shall be increase by 50% in the perimeter area (minimum 12') in order to achieve a maximum **peak gust wind speed** coverage on the warranty of **120 mph**.
- i. **7/16" OSB Board** shall be fastened with a minimum of **17 fasteners/plates** per 4' x 8' board to achieve a maximum **peak gust wind speed of 100 mph**. A fastening density of **17 fasteners/plates** per 4' x 8' board plus **50% increase** in fastening in the **perimeter area** (minimum 12' wide) will qualify the project for a maximum **peak gust wind speed of 120 mph**.

**Note:** Use of FAST Adhesive to attach OSB to other Versico insulation is not recommended. OSB/Polyiso Composite Board may be specified and can be attached with either FAST Adhesive or mechanical fasteners.

### E. Metal Accessories (for both Mechanically Attached or Fully Adhered Assemblies)

The use of the **TPO PS Coverstrip** is **not permitted** to flash metal flanges of edge metal fascia systems.

1. For projects with a warranty wind speed coverage of 90 mph or greater, Versico VersiTrim™ 2000 Metal Fascia must be used.
2. For projects with a warranty wind speed less than 90 mph, Versico VersiTrim, VersiTrim 1000, or VersiTrim 200 may be used. Metal Edging formed with VersiWeld Coated Metal may also be used and shall be fastened staggered at 4" on center. Along gutters the Versico Termination Bar or VersiWeld Coated Metal may be used

**Note:** In lieu of ring shank nails staggered at 4" on center, HPV or HPVX Fasteners may be used at 12" on center to secure the VersiTrim Metal Fascia.

3. Versico Termination Bar is required in locations where a compression bar termination has been specified. The Termination Bar must also be used in conjunction with new or existing counterflashing.
4. Certain metal accessories by others may be permitted upon Versico acceptance for wind speed coverage less than 90 mph.  
**Note:** Conventional metal fascia systems that require flanges to be "stripped in" are not permitted.
5. When a warranty wind speed of 80 mph or greater is desired, air infiltration must be prevented along the roof edge by adhering the membrane over the perimeter wood nailers and down the outside face of the building.

# VersiWeld Mechanically Attached and Fully Adhered Roofing Systems

## "Attachment VI"

### Construction Generated Moisture

August 2008

- A. While buildings should ultimately be designed to fit their intended purpose and accommodate their occupants, they must also tolerate various construction conditions (i.e., time of construction, material and process used).

In cold climatic regions, buildings in their construction phase will most likely experience an aggressive upward moisture drive as a result of hydration of freshly poured concrete floors and the practice of using oil or propane fired heaters.

#### According to NRCA:

1. Construction processes can release large quantities of water vapor. For example, wall or ceiling plaster or 4" thick concrete slabs release roughly one quart of water (2 pounds) for each square foot of surface area during the drying process. A building that is 120,000 square feet in size could experience up to 30,000 gallons of construction-generated moisture.
2. The combustion process of an oil-or propane-fired heater, used for temporary heat during construction, produces more water as a by-product of burning than the weight of the fuel consumed. Approximately one gallon of water will be produced for each gallon of heating oil burned. This generated moisture, if not addressed through ventilation or contained using vapor retarders, will subject the roof assembly to potential harmful effects that vary from mold accumulation to reduced insulation efficiency.

#### B. Moisture Migration

Moisture vapor penetrates a roof assembly either by **air leakage** or by **diffusion**.

1. **Air leakage** occurs through joints in the metal deck or tilt-up panels, insulation and joints and gaps around penetrations. Air leakage will also occur as a result of imperfections, such as punctures and tears.
2. **Diffusion** of moisture is caused by the differences in vapor pressure that occur with varying temperature conditions and relative humidities. The greater the temperature differential, the more active the moisture drive.

Air leakage can allow the transport of significantly greater amounts of moisture than can be transported by way of diffusion.

#### C. Impact of Air Leakage

Warm, humid air that infiltrates through gaps and joints will begin condensing beneath the roofing membrane and could freeze in colder temperatures. Hot, humid air will always seek the path of least resistance, thus, insulation joints become the most common route. High levels of moisture condensing along the insulation joints could eventually break the cell structure of polyiso insulation allowing gases to escape, which in turn promotes board shrinkage and possible edge collapse.

#### D. Preventing Moisture Damage

While occupancy generated moisture is usually addressed through the use of a vapor retarder, construction generated moisture can be addressed by simply incorporating multiple layers of insulation and staggering the joints. This will significantly reduce air leakage, which is responsible for the transport of greater amounts of moisture into the assembly.

NRCA recommends 2 or more layers of roof insulation, which has long been recognized as an advantage in terms of eliminating heat transfer and maximizing roof system efficiency. Studies have also revealed an 8 - 10 % reduction in energy costs between assemblies with equal R-Value when designed with multiple layers versus those designed with a single layer of insulation.

**VersiWeld Mechanically Attached Roofing Systems**  
**“Attachment VII”**  
**30-Year Warranty - Design Enhancements**  
August 2008

Information contained in this Attachment outlines necessary enhancements required for projects where a 30-year Total System Warranty is specified. At the applicator's or specifier's discretion, projects may be forwarded to Versico for evaluation prior to installation or bid.

**A. Design Criteria**

1. Minimum 80-mil thick VersiWeld Reinforced Membrane is required. All “T” joints must be overlaid with VersiWeld “T” Joint Covers or VersiWeld Non-Reinforced Flashing heat welded on all sides.
2. The building height shall not exceed 45'. Projects that exceed 45' in height or require a peak gust wind speed warranty greater than 90 mph must be forwarded to Versico for review.
3. A minimum slope of 1/4" per horizontal foot is preferred; however, 1/8" slope with sufficient number of drains and crickets/saddles may be accepted.
4. All products specified for this roofing assembly must be products manufactured or marketed by Versico.
5. On retrofit projects all existing roofing materials must be totally removed.
6. For all projects, a final shop drawing must be approved by Versico prior to installation. Shop drawings must include all pertaining details. **No As-Built projects are permitted.**
7. The roof assembly will vary based on warranty wind speed. Refer to Paragraph D, Membrane Fastening Requirements, for specific assembly requirements.

**B. Roof Deck Criteria**

1. **Steel (22 gauge or heavier)** – HPVX Fasteners and HPVX Plates or HPV-XL Fasteners and HPV-XL Plates are required with a minimum pullout of 500 pounds per fastener.
2. **Structural Concrete (minimum 3,000 psi)** – Versico CD-10 (hammer-driven) or MP 14-10 (threaded) Fasteners with HPVX Plates are required with a minimum pullout of 800 pounds per fastener.
3. **Wood Plank (minimum 1-1/2" thick) or minimum 15/32" thick Plywood** – Versico HPVX Fasteners and HPVX Plates or HPV-XL Fasteners and HPV-XL Plates are required with a minimum pullout of 360 pounds.

For consideration of other deck types, contact Versico for evaluation prior to installation or bid.

**C. Acceptable Insulation/Underlayment**

1. Versico Polyisocyanurate (20 or 25 psi compressive strength).
2. HP Recovery Board or Dens-Deck/Dens-Deck Prime **over any Versico insulation.**
3. Versico FR Base Sheet may be approved to meet certain fire codes over combustible roof decks.

4. **Insulation Securement** - HP Recovery Board, Dens-Deck/Dens-Deck Prime or Polyisocyanurate Insulation fastened with 6 fasteners/plates per 4' x 8' board (1 per 5.3 square feet). When 4' x 4' boards are used 4 fasteners/plates are required (1 per 4 square feet).

#### D. Membrane Fastening Requirements

1. On steel and wood decks, HPVX Fasteners/HPVX Plates or HPV-XL Fasteners/HPV-XL Plates must be used. Assemblies where the fastener length is expected to exceed 6" in length must be submitted to Versico to determine a suitable fastening density.
2. On structural concrete decks, CD-10 or MP 14-10 Fasteners shall be used with HPVX.
3. **Perimeter/Field Membrane Securement:**

Wind Speed	Deck Type	Perimeter Sheets		Perimeter Fastening Density	Field Sheets		Fasteners/Plates
		# of Sheets	Width		Width	Fastening Density	
55 MPH	Steel or 1-1/2" thick Wood Plank	2	4'	Same as Field Fastening Density	8'	12" o.c.	HVVX Fasteners/ HPVX Plates
	3/4" thick Plywood				8'	9" o.c.	HPVX Fastener/ HPVX Plates
	Steel		6'		10'	12" o.c.	HPV-XL Fasteners HPV-XL Plates
	Structural Concrete				10'	12" o.c.	CD-10 or MP 14-10/ HPVX Plates
	Steel or 1-1/2" thick Wood Plank				10'	6" o.c.	HPVX Fasteners/ HPVX Plates
72 MPH	Same as 55 MPH See above	3	4'		Same criteria as 55 MPH - See above		
			6'		Same Criteria as 55 MPH - See above		
80 MPH	Steel or 1-1/2" thick wood plank	4	4'		8'	12" o.c.	HPVX Fastener/ HPVX Plates
			6'		10'	6" o.c.	
	3/4" thick Plywood		4'		8'	12" o.c.	HPVX Fasteners/ HPVX Plates
			6'	10'	6" o.c.		
	Structural Concrete	3	4'	8'	12" o.c.	CD-10 or MP 14-10/ HPVX Plates	
			6'	10'	9" o.c.		
90 MPH See Note Below	Steel or 1-1/2" thick wood plank	5	4'	8'	12" o.c.	HPVX Fasteners/ HPVX Plates	
			6'	10'	6" o.c.		
	Structural Concrete	4	4'	8'	12" o.c.	CD-10 or MP 14-10/ HPVX Plates	
			6'	10'	6" o.c.		

Note: Can be installed directly over Versico Polyisocyanurate or SecurShield Polyiso minimum 25 psi or 20 psi or 1 pound density EPS overlaid with 1/4" thick Dens-Deck or 1/2" thick HP Recovery Board.

#### E. Metal Accessories

The use of the VersiWeld Pressure Sensitive Cover Strip is not permitted to flash metal flanges.

1. For projects with a warranty wind speed coverage of 90 mph or greater, Versico's VersiTrim 2000 Metal Fascia must be used.

2. For projects with a warranty wind speed less than 90 mph, Versico's VersiTrim, VersiTrim 1000, or VersiTrim 200 may be used. Metal Edging formed with VersiWeld Coated Metal may also be used and shall be fastened staggered at 4" on center. Along gutters the Versico Termination Bar or VersiWeld Coated Metal may be used.

**Note:** In lieu of ring shank nails staggered at 4" o. c., HP or HP-X Fasteners may be used at 12" o. c. to secure the VersiTrim Metal Fascia.

3. Versico Termination Bar is required in locations where a compression bar termination has been specified. The Termination Bar must also be used in conjunction with new or existing counterflashing.
4. Where new or existing counterflashing is used, Versico's Termination Bar must also be used as the primary termination.
5. Certain metal accessories by others may be permitted upon Versico acceptance for wind speed coverage less than 90 mph.
6. Coated metal edge systems may be used on projects not greater than 45 feet in height with wind speed coverage of 55 mph. The edge detail must be submitted and approved by Versico prior to installation. **No As-Built projects are permitted.**
7. When a warranty wind speed of 80 mph or greater is desired, air infiltration must be prevented along the roof edge by adhering the membrane over perimeter wood nailers, down the outside face of the building.

## F. Flashing

1. Minimum 60-mil thick VersiWeld membrane must be used for flashing.
2. All existing flashing must be removed prior to the application of new membrane. New membrane flashing must not conceal weep holes or cover existing through wall counterflashing.
3. Wall flashings shall extend a minimum of 8" above the roof surface.
4. Pre-fabricated accessories must be utilized.
5. Project details must be reviewed by Versico, preferably prior to bid, and a written approval must be obtained. As a warranty prerequisite, the approval shall be included as part of the project submittals along with the Request for Warranty form that is required for project approval.

# VersiWeld Fully Adhered Roofing Systems

## "Attachment VIII"

### 30-Year Warranty - Design Enhancements

August 2008

Information contained in this Attachment outlines necessary enhancements required for projects where a 30-year Total System Warranty is specified. At the contractor's or specifier's discretion, projects may be forwarded to Versico for evaluation prior to installation or bid.

#### A. Design Criteria

1. The roofing membrane shall be a minimum of 80-mil thick VersiWeld Reinforced Membrane with all "T" joints overlaid with VersiWeld "T" Joint Covers or VersiWeld Non-Reinforced Flashing heat welded on all sides.
2. The building Height shall not exceed 100'.
3. A minimum slope of ¼" per horizontal foot is preferred; however, 1/8" slope with sufficient number of drains and crickets/saddles may be accepted.
4. All products specified for this roofing assembly must be products manufactured or marketed by Versico.
5. On retrofit projects, all existing roofing material must be totally removed.
6. For all projects, a final shop drawing must be approved by Versico prior to installation. Shop drawings must include all pertaining details. **No As-Built projects are permitted.**
7. The roof assembly will vary based on warranty wind speed and hail coverage. Refer to Paragraph D, Design Options, for specific assembly requirements.

#### B. Roof Deck Criteria

1. **Steel (22 gauge or heavier)** - HPVX Fasteners are required with a minimum pullout of 360 pounds per fastener.
2. **Structural Concrete (minimum 3,000 psi)** – CD-10 (Nail-In) or MP 14-10 (threaded) Fasteners are required with a minimum pullout of 800 pounds per fastener. FAST Adhesive is an acceptable alternate.
3. **Wood Plank (minimum 1-1/2" thick) or minimum 15/32" thick Plywood** – HPVX Fasteners are required with a minimum pullout of 360 pounds.
4. **Cementitious Wood Fiber and Gypsum** (limited to maximum warranty wind speed of 72 mph) – NTB or Lite Deck (gypsum decks only) Fasteners are required with a minimum pullout of 225 pounds for cementitious wood fiber decks and 300 pounds for gypsum decks.

For consideration of other deck types, contact Versico for evaluation prior to installation or bid.

#### C. Acceptable Insulation/Underlayment

1. Minimum 1-1/2" thick Versico MP-H Polyisocyanurate Insulation or SecurShield Polyiso (20 or 25 psi compressive strength). For Factory Mutual (FM) compliance, refer to the Versico Code Approval Guide, published separately, for required minimum insulation thickness.
2. Versico Recovery Board or Dens-Deck Prime **over any Versico Insulation.**  
**Note:** Versico Recovery Board or Dens-Deck Prime may only be use on top of Versico insulation. Their direct use over any existing roofing membrane or roof deck is not permitted.

3. Minimum 7/16" OSB over any Versico Insulation or OSB/Polyiso Composite.

## D. Design Options

In addition to the **puncture and hail resistance coverage** associated with the 30-year Total System Warranty, the **wind speed coverage** is influenced by the roof assembly selected and the use of specific membrane underlayments to which the membrane is to be adhered.

### 1. Projects with Hail Coverage

- a. **Projects with 100 mph peak gust wind speed** (not applicable for oriented strand board, plywood, fibrous cement, or gypsum decks)

The membrane assembly must incorporate Versico Polyisocyanurate/OSB Composite Insulation or 7/16" thick Oriented Strand Board (OSB) installed over a base layer of Versico Polyisocyanurate insulation (standard 20 psi compressive strength) or other acceptable Versico insulation with all joints staggered between layers. Layers of insulation may be mechanically fastened or FAST Adhesive may be used to adhere the top layer of Versico Polyiso/OSB Composite insulation.

- b. **Projects with 72 mph peak gust wind speed**

The membrane assembly must incorporate **1/2" thick Dens-Deck Prime (supplied by Versico)** as a membrane underlayment installed over a base layer of Versico Polyisocyanurate insulation (standard 20 psi compressive strength) or other acceptable Versico insulation with all joints staggered between layers. Both layers may be mechanically fastened or adhered with FAST Adhesive (required for fibrous cement or gypsum decks), where applicable.

**Note:** On fibrous cement or gypsum decks, the use of Versico Polyiso/OSB Composite insulation is required in order to obtain the 72 mph peak gust wind speed coverage. The composite board must be attached with FAST Adhesive if specified as a single layer (maximum thickness 2-1/2"). In multiple layer applications, the bottom layer shall be Versico Polyiso or other acceptable Versico Insulation and all layers shall be secured with FAST Adhesive.

- c. **Projects with 55 mph peak gust wind speed**

The membrane assembly must incorporate 1/2" thick HP Recovery Board or minimum 1/4" thick Dens-Deck Prime (supplied by Versico) installed over a base layer of Versico Polyisocyanurate insulation (standard 20 psi compressive strength) or other acceptable Versico insulation with all joints staggered between layers. Both layers or the bottom layer may be mechanically fastened. FAST Adhesive may be used to adhere the top layer (HP Recovery Board or minimum 1/2" thick Dens-Deck Prime).

**Note:** The use of FAST Adhesive is not permitted to attach 1/4" thick Dens-Deck Prime.

### 2. Projects with No Hail Coverage

- a. **Projects with 55 mph peak gust wind speed**

- 1) The membrane assembly may incorporate a top layer of Versico Polyisocyanurate MP-H insulation with minimum 25 psi compressive strength and a thickness between 1.5" and 2.5" thick, installed over a base layer of Versico Polyisocyanurate insulation with standard 20 psi compressive strength with all joints staggered between layers. Both layers may be mechanically fastened or adhered with FAST Adhesive, where applicable.

- 2) The membrane assembly may also incorporate a single layer of Versico Polyisocyanurate Insulation with 25 psi compressive strength and a thickness between 2" to 2.5" if the board is to be mechanically

fastened. Where FAST Adhesive is permitted, the thickness of the single layer shall be between 1.5" to 2.5".

b. **Projects with 72 mph peak gust wind speed**

- 3) The membrane assembly must incorporate a top layer of Versico SecurShield Polyiso insulation with minimum 25 psi compressive strength and a thickness between 2.0" and 2.5" thick, installed over a base layer of Versico Polyisocyanurate insulation with standard 20 psi compressive strength with all joints staggered between layers. Both layers may be mechanically fastened or adhered with FAST Adhesive, where applicable.
- 4) The membrane assembly may also incorporate a single layer of Versico Polyisocyanurate Insulation with 25 psi compressive strength and a thickness between 2" to 2.5" if the board is to be mechanically fastened. Where FAST Adhesive is permitted, the thickness of the single layer shall be between 1.5" to 2.5".

**E. Insulation/Underlayment Attachment**

1. Versico Polyisocyanurate Insulation, Oriented Strand Board (OSB)/Polyisocyanurate Composite, and HP Recovery Board or Dens-Deck Prime over an approved Versico insulation shall be mechanically fastened to the roof deck with 1 insulation fastener and plate every 2 square feet.
2. When 7/16" thick Oriented Strand Board is used as a membrane underlayment over an approved Versico insulation, it shall be mechanically fastened at the minimum rate of 17 fasteners and plates per 4' x 8' board. Oriented Strand Board cannot be attached with FAST Adhesive. When the use of FAST Adhesive is desired in conjunction with OSB, an OSB/ Polyisocyanurate Composite board must be used.

**Note:** HP Recovery Board, Dens-Deck Prime and Oriented Strand Board can only be used as a membrane underlayment in conjunction with an approved Versico insulation.

3. In roof assemblies with multiple layers of insulation, both insulation layers may be mechanically fastened or mechanical fasteners may be limited to the bottom layer and FAST Adhesive may be used to attach the top layer.
4. When mechanical attachment of the insulation is not desired over structural concrete, cementitious wood fiber and gypsum decks, an alternate insulation attachment method using FAST Adhesive may be specified.

**Note:** FAST Adhesive cannot be used to attach insulation to steel decks.

**F. Metal Accessories**

The use of the **Versico's TPO Pressure-Sensitive Cover Strip** is **not permitted** to flash metal flanges of edge metal fascia systems.

1. For projects with a warranty wind speed coverage of 100 mph or greater, Versico VersiTrim 2000 or 3000 Metal Fascia must be used.
2. For projects with a warranty wind speed less than 100 mph, VersiTrim 1000, or VersiTrim 200 may be used. Metal Edging formed with VersiWeld Coated Metal may also be used and shall be fastened staggered at 4" on center. Along gutters the Versico Termination Bar or VersiWeld Coated Metal may be used

**Note:** In lieu of ring shank nails staggered at 4" o. c., HP or HPVX Fasteners may be used at 12" o. c. to secure the VersiTrim Metal Fascia.

3. Versico Termination Bar is required in locations where a compression bar termination has been specified. The Termination Bar must also be used in conjunction with new or existing counterflashing.

4. Where new or existing counterflashing is used, Versico's Termination Bar must also be used as the primary termination.
5. Certain metal accessories by others may be permitted upon Versico acceptance for wind speed coverage less than 72 mph.
6. Coated metal edge systems may be used on projects not greater than 45 feet in height with wind speed coverage of 55 mph. The edge detail must be submitted and approved by Versico prior to installation. **No As-Built projects are permitted.**
7. When a warranty wind speed of 72 mph or greater is desired, air infiltration must be prevented along the roof edge by adhering the membrane over perimeter wood nailers, down the outside face of the building.

## G. Flashing

1. Minimum 60-mil thick VersiWeld membrane must be used for flashing.
2. All existing flashing must be removed prior to the application of new membrane. New membrane flashing must not conceal weep holes or cover existing through wall counterflashing.
3. Wall flashings shall extend a minimum of 8" above the roof surface.
4. Pre-fabricated accessories must be utilized.

Project details must be reviewed by Versico, preferably prior to bid, and a written approval must be obtained. As a warranty prerequisite, the approval shall be included as part of the project submittals along with the Request for Warranty form that is required for project approval.

# Metrics

## Length

.045 inch = 1.1 mm  
.060 inch = 1.5 mm  
1/8 inch = 3 mm  
1/4 inch = 6 mm  
7/16 inch = 11 mm  
15/32 inch = 12 mm or 1.2 cm  
1/2 inch = 13 mm or 1.3 cm  
9/16 inch = 14 mm  
5/8 inch = 16 mm or 1.6 cm  
3/4 inch = 19 mm or 1.9 cm  
1 inch = 2.5 cm  
1-1/4 inches = 3.8 cm  
1-1/2 inches = 4 cm  
2 inches = 5 cm  
2-1/2 inches = 6.4 cm  
3 inches = 8 cm  
3-1/4 inches = 8.3 cm  
4 inches = 10.5 cm  
5 inches = 12.7 cm  
5-1/2 inches = 14 cm  
6 inches = 16.5 cm  
9 inches = 23 cm  
10 inches = 25 cm  
12 inches = 31 cm  
18 inches = 46 cm  
24 inches = 61 cm  
3 feet = .9 m  
3 feet, 6 inches = 1.1 m  
4 feet = 1.2 m  
4 feet, 6 inches = 1.4 m  
5 feet = 1.5 m  
6 feet = 1.8 m  
8 feet = 2.4 m  
10 feet = 3 m  
12 feet = 3.7 m  
12.5 feet = 3.8 m  
15 feet = 4.6 m  
33 feet = 10 m  
50 feet = 15.2 m  
75 feet = 22.9 m  
100 feet = 30 m  
225 feet = 69 m  
250 feet = 76.2 m  
275 feet = 84 m

10 feet per minute = 3 m per minute  
15 feet per minute = 4.6 m per minute  
2 inches in 12 inches = 16 cm/m  
3 inches in 1 horizontal foot = 25 cm/m  
5 inches in 12 inches = 41 cm/m  
18 inches in 12 inches = 150 cm/m

1 per 2 square feet = 1 per 1.86 m<sup>2</sup>

1 per 4 square feet = 1 per 3.72 m<sup>2</sup>  
1 per 5.3 square feet = 1 per 4.93 m<sup>2</sup>  
1 per 6.4 square feet = 1 per 5.95 m<sup>2</sup>

60 square feet/gallon = 5.6 m<sup>2</sup>/liter  
120 square feet/gallon = 11.1 m<sup>2</sup>/liter  
225 linear feet = 69 m  
275 linear feet = 84 m  
600 linear feet = 183 m

## Weight

80 pounds = 36 kg  
300 pounds = 136 kg  
360 pounds = 163 kg  
500 pounds = 227 kg  
800 pounds = 363 kg

## Miles Per Hour

55 mph = 34 km per hour  
72 mph = 45 km per hour  
79 mph = 49 km per hour  
80-89 mph = 50 – 55 km per hour  
90-99 mph = 56 – 61.5 km per hour  
100 mph = 62.1 km per hour

## Fahrenheit/Celsius

40° Fahrenheit = 4.5° Celsius  
90° Fahrenheit = 32° Celsius  
120° Fahrenheit = 49° Celsius  
1000° Fahrenheit = 538° Celsius  
1004° Fahrenheit = 540° Celsius

## Pressure

3000 psi = 211kg/cm<sup>2</sup>

## Volume

1 gallon – 3.78 liter  
5 gallon – 18.9 liter

22 gauge - .75 m